

OPERATOR'S MANUAL



Model 60 and 62 Shake Freezers

Original Operating Instructions

051059-M

**4/00 (Original Publication)
(Updated 4/28/2023)**

Complete this page for quick reference when service is required:

Taylor distributor: _____

Address: _____

Phone: _____

Service: _____

Parts: _____

Date of Installation: _____

Information found on the data label:

Model Number: _____

Serial Number: _____

Electrical Specs: Voltage _____ Cycle _____

 Phase _____

Maximum Fuse Size: _____ A

Minimum Wire Ampacity: _____ A

Note: *Continuing research results in steady improvements; therefore, information in this manual is subject to change without notice.*

Note: *Only instructions originating from the factory or its authorized translation representative(s) are considered to be the original set of instructions.*

© March 2000 Taylor Company (Original Publication)

(Updated 4/28/2023)

051059-M

Any unauthorized reproduction, disclosure, or distribution of copies by any person of any portion of this work may be a violation of Copyright Law of the United States of America and other countries, could result in the awarding of Statutory Damages of up to \$250,000 (17 USC 504) for infringement, and may result in further civil and criminal penalties. All rights reserved.



Taylor Company
750 N. Blackhawk Blvd.
Rockton, IL 61072



Section 1: To the Installer

Installer Safety	1-1
Air-Cooled Machines	1-1
Water Connections	1-2
Electrical Connections	1-2
Refrigerant	1-3

Section 2: To the Operator

Compressor Warranty Disclaimer	2-1
--	-----

Section 3: Safety

Section 4: Operator Parts Identification

Model 60 Exploded View	4-1
Model 62 Exploded View	4-2
Door and Beater Assembly	4-3
Accessories	4-4

Section 5: User Interface

Symbol Definitions	5-2
Control Switch	5-2
Dial Light	5-2
Indicator Light—MIX LOW	5-2
Indicator Light—MIX OUT	5-2
Reset Mechanism	5-2
Consistency Control	5-3
Spinner Rinse Switch	5-3
Auto Lift Switch (Model 60 Only)	5-3
Foot Pedal (Model 60 Only)	5-3
Flavor Selector Switch	5-3

Table of Contents

Section 6: Operating Procedures

Assembly	6-1
Sanitizing	6-6
Priming	6-7
Syrup System	6-8
Drawing Product	6-11
Closing Procedures	6-12
Draining Product From the Freezing Cylinder	6-12
Rinsing	6-12
Cleaning	6-13
Disassembly	6-13
Brush-Cleaning	6-13
Sanitizing Syrup System	6-14

Section 7: Operator's Checklist

During Cleaning and Sanitizing	7-1
Troubleshooting Bacterial Count	7-1
Regular Maintenance Checks	7-1
Winter Storage	7-2

Section 8: Troubleshooting Guide

Section 9: Parts Replacement Schedule

Section 10: Limited Warranty on Equipment

Section 11: Limited Warranty on Parts

The following information has been included in the manual as safety and regulatory guidelines. For complete installation instructions, please see the installation checklist.

Installer Safety



IMPORTANT! *In all areas of the world, machines should be installed in accordance with existing local codes. Please contact your local authorities if you have any questions.*

Care should be taken to ensure that all basic safety practices are followed during the installation and servicing of Taylor machines.

- *Only Taylor service technicians should perform installation, maintenance, and repairs on Taylor machines.*
- *Taylor service technicians should consult OSHA Standard 29CFR1910.147 or the applicable code of the local area for industry standards on lockout/tagout procedures before beginning any installation or repairs.*
- *Taylor service technicians must ensure that the proper personal protective equipment (PPE) is available and worn when required during installation and service.*
- *Taylor service technicians must remove all metal jewelry, rings, and watches before working on electrical equipment.*



DANGER! The main power supply(s) to the machine must be disconnected prior to performing any installation, maintenance, or repairs. Failure to follow this instruction may result in personal injury or death from electrical shock or hazardous moving parts, as well as poor performance or damage to the machine.



WARNING! This machine has many sharp edges that can cause severe injuries.

Site Preparation

Review the area where the machine will be installed before uncrating it. Make sure all possible hazards to the user or machine have been addressed.

Uncrate the machine and inspect it for damage. Report any damage to the Taylor distributor.

This machine is made in the USA and uses USA hardware sizes. All metric conversions are approximate.

For Indoor Use Only: This machine is designed to operate indoors, under normal ambient temperatures of 70°F to 75°F (21°C to 24°C). The freezer has successfully performed in high ambient temperatures of 104°F (40°C) at reduced capacities.



WARNING! This machine must **NOT** be installed in an area where a water jet or hose can be used. **NEVER** use a water jet or hose to rinse or clean the machine. Failure to follow this instruction may result in electrocution.



CAUTION! This machine must be installed on a level surface to avoid the hazard of tipping. Extreme care should be taken in moving this machine for any reason. Two or more persons are required to safely move this machine. Failure to comply may result in personal injury or machine damage.

Air-Cooled Machines

Do not obstruct air intake and discharge openings:

Air-cooled machines require a minimum of 6 in. (152 mm) of clearance around all sides and 7- 1/2 in. (191 mm) on the bottom to allow for adequate airflow across the condenser. Failure to provide this clearance can reduce the refrigeration capacity of the freezer and possibly cause permanent damage to the compressor.

Water Connections

(Water-Cooled Machines Only)

An adequate cold water supply must be provided with a hand shutoff valve. On the underside rear of the base pan, two 3/8 in. I.P.S. water connections for inlet and outlet have been provided for easy hookup. The 1/2 in. inside diameter water lines should be connected to the machine. (Flexible lines are recommended, if local codes permit.) Depending on local water conditions, it may be advisable to install a water strainer to prevent foreign substances from clogging the automatic water valve. There will be only one water-in and one water-out connection. **Do not** install a hand shutoff valve on the water-out line. Water should always flow in this order: first, through the automatic water valve; second, through the condenser; and third, through the outlet fitting to an **open trap drain**.



IMPORTANT! A backflow prevention device is required on the incoming water connection side. Please see the applicable national, state, and local codes for determining the proper configuration.

Electrical Connections

In the United States, this machine is intended to be installed in accordance with the National Electrical Code (NEC), ANSI/NFPA 70-1987. The purpose of the NEC code is the practical safeguarding of persons and property from hazards arising from the use of electricity. This code contains provisions considered necessary for safety. In all other areas of the world, machines should be installed in accordance with the existing local codes. Please contact your local authorities.



FOLLOW YOUR LOCAL ELECTRICAL CODES.

Each freezer requires one power supply. Check the data label on the freezer for branch circuit overcurrent protection or fuse, circuit ampacity, and electrical specifications. Refer to the wiring diagram provided inside of the control box for proper power connections.



WARNING! This machine must be properly grounded. Failure to do so can result in severe personal injury from electrical shock.



IMPORTANT! This machine is provided with an equipotential grounding lug that is to be properly attached to the rear of the frame by the authorized installer. The installation location is marked by the equipotential bonding symbol (5021 of IEC 60417-1) on the removable panel and the frame.



IMPORTANT!

- Stationary machines which are not equipped with a power cord and a plug or another device to disconnect the machine from the power source must have an all-pole disconnecting device with a contact gap of at least 0.125 in. (3 mm) in the external installation.
- Machines that are permanently connected to fixed wiring and for which leakage currents may exceed 10 mA, particularly when disconnected or not used for long periods, or during initial installation, shall have protective devices to protect against the leakage of current, such as a GFI, installed by authorized personnel to local codes.
- Supply cords used with this machine shall be oil-resistant, sheathed flexible cable not lighter than ordinary polychloroprene or other equivalent synthetic elastomer-sheathed cord (code designation 60245 IEC 57) installed with the proper cord anchorage to relieve conductors from strain, including twisting, at the terminals and protect the insulation of the conductors from abrasion.
If the supply cord is damaged, it must be replaced by a Taylor service technician to avoid a hazard.

Beater Rotation



NOTICE! Beater rotation must be clockwise as viewed looking into the freezing cylinder.

To correct the rotation on a three-phase machine, interchange any two incoming power supply lines at the freezer main terminal block only.

To correct rotation on a single-phase machine, exchange leads inside the beater motor. (Follow the diagram printed on the motor.)

Electrical connections are made directly to the terminal block provided in the main control box, located on the right side of the machine.

It is recommended that beater rotation adjustment be performed by a Taylor service technician.



WARNING! Refrigerant liquid sprayed onto the skin may cause serious damage to tissue. Keep eyes and skin protected. If refrigerant burns should occur, flush the area immediately with cold water. If burns are severe, apply ice packs and contact a physician immediately.



NOTICE! Taylor reminds technicians to be aware of and in compliance with local government laws regarding refrigerant recovery, recycling, and reclaiming systems. For information regarding applicable local laws, please contact your local authorized Taylor distributor.

Refrigerant



CAUTION! This machine contains fluorinated greenhouse gases (F-Gas) to provide refrigeration using a hermetically sealed circuit or within foam insulation. This machine's type of gas, quantity, Global Warming Potential (GWP), and CO₂ tonnes equivalent information is recorded on the machine's data label. The refrigerant used is generally considered nontoxic and nonflammable. However any gas under pressure is potentially hazardous and must be handled with caution.

NEVER fill any refrigerant cylinder completely with liquid. Filling the cylinder approximately 80% will allow for normal expansion.



CAUTION! Use only approved refrigerant listed on the machine's data label or authorized through a manufacturer's technical bulletin. The use of any other refrigerant may expose users and operators to unexpected safety hazards.



IMPORTANT! Refrigerants and their associated lubricants may be extremely moisture absorbent. When opening a refrigeration system, the maximum time the system is open must not exceed 15 minutes. Cap all open tubing to prevent humid air or water from being absorbed by the oil.

The freezer you have purchased has been carefully engineered and manufactured to give you dependable operation. The Taylor Models 60 and 62, when properly operated and cared for, will produce a consistent quality product. Like all mechanical products, these machines will require cleaning and maintenance. A minimum amount of care and attention is necessary if the operating procedures outlined in this manual are followed closely.

This Operator's Manual should be read before operating or performing any maintenance on your machine.

Taylor Models 60 and 62 will **not** eventually compensate for and correct any errors during the setup or filling operations. Thus, the initial assembly and priming procedures are of extreme importance. It is strongly recommended that personnel responsible for the machine's operation, both assembly and disassembly, go through these procedures together to be properly trained and to make sure that no confusion exists.

If you require technical assistance, please contact your local Taylor distributor.

Note: *Your Taylor warranty is valid only if the parts are authorized Taylor parts, purchased from the local authorized Taylor distributor, and only if all required service work is provided by a Taylor service technician. Taylor reserves the right to deny warranty claims on machines or parts if non-Taylor-approved parts or incorrect refrigerant were installed in the machine, system modifications were performed beyond factory recommendations, or it is determined that the failure was caused by abuse, misuse, neglect, or failure to follow all operating instructions. For full details of your Taylor warranty, please see the Limited Warranty section in this manual.*



IMPORTANT! *If the crossed-out wheeled bin symbol is affixed to this machine, it signifies that this machine is compliant with the EU directives as well as other similar end-of-life legislation in effect after August 13, 2005. Therefore, it must be collected separately after its use is completed and cannot be disposed as unsorted municipal waste.*

The user is responsible for delivering the machine to the appropriate collection facility as specified by your local code.

For additional information regarding applicable local disposal laws, please contact the municipal waste facility and/or local authorized Taylor distributor.

Compressor Warranty Disclaimer

The refrigeration compressor(s) on this machine are warranted for the term stated in the Limited Warranty section in this manual. However, due to the Montreal Protocol and the U.S. Clean Air Act Amendments of 1990, many new refrigerants are being tested and developed, thus seeking their way into the service industry. Some of these new refrigerants are being advertised as drop-in replacements for numerous applications. It should be noted that in the event of ordinary service to this machine's refrigeration system, **only the refrigerant specified on the affixed data label should be used.** The unauthorized use of alternate refrigerants will void your Taylor compressor warranty. It is the machine owner's responsibility to make this fact known to any technician they employ.

It should also be noted that Taylor does not warrant the refrigerant used in its machines. For example, if the refrigerant is lost during the course of ordinary service to this machine, Taylor has no obligation to either supply or provide its replacement either at billable or unbillable terms. Taylor does have the obligation to recommend a suitable replacement if the original refrigerant is banned, obsoleted, or no longer available during the 5-year warranty of the compressor.

The Taylor Company will continue to monitor the industry and test new alternates as they are being developed. Should a new alternate prove, through our testing, that it would be accepted as a drop-in replacement, then the above disclaimer would become null and void. To find out the current status of an alternate refrigerant as it relates to your compressor warranty, call the local Taylor distributor or the Taylor factory. Be prepared to provide the model and serial number of the machine in question.

We at Taylor Company are concerned about the safety of the operator when he or she comes in contact with the freezer and its parts. Taylor has gone to extreme efforts to design and manufacture built-in safety features to protect both the operator and the service technician. As an example, warning labels have been attached to the freezer to further point out safety precautions to the operator.



DANGER! Failure to adhere to the following safety precautions may result in severe personal injury or death. Failure to comply with these warnings may also damage the machine and/or its components. Such damage may require component replacement and service repair expenses.



NOTICE! DO NOT operate the machine without reading the Operator's Manual. Failure to follow this instruction may result in machine damage, poor machine performance, health hazards, or personal injury.



IMPORTANT! *This machine is to be used only by trained personnel. It is not intended for use by children or people with reduced physical, sensory, or mental capabilities, or lack of experience and knowledge, unless given supervision or instruction concerning the use of the machine by a person responsible for their safety.*

Children should be supervised to ensure that they do not play with the machine.



IMPORTANT! *This machine is provided with an equipotential grounding lug that is to be properly attached to the rear of the frame by the authorized installer. The installation location is marked by the equipotential bonding symbol (5021 of IEC 60417-1) on the removable panel and the frame.*



WARNING! Avoid injury.

- **DO NOT** operate this machine unless it is properly grounded.
- **DO NOT** operate this machine with fuses larger than specified on the data label.
- **DO NOT** operate this machine unless all service panels and access doors are attached with screws.
- All repairs must be performed by an authorized Taylor service technician.
- The main power supplies to the machine must be disconnected prior to performing any repairs.
- Only Taylor service technicians or licensed electricians may install a plug or replacement cord on this machine.
- Stationary machines which are not equipped with a power cord and a plug or other device to disconnect the machine from the power source must have an all-pole disconnecting device with a contact gap of at least 1/8 in. (3 mm) installed in the external installation.
- Machines that are permanently connected to fixed wiring and for which leakage currents may exceed 10 mA, particularly when disconnected or not used for long periods, or during initial installation, shall have protective devices such as a GFI to protect against the leakage of current installed by the authorized personnel to the local codes.
- Supply cords used with this machine shall be oil-resistant, sheathed flexible cable not lighter than ordinary polychloroprene or other equivalent synthetic elastomer-sheathed cord (code designation 60245 IEC 57) installed with the proper cord anchorage to relieve conductors from strain, including twisting, at the terminals and protect the insulation of the conductors from abrasion. If the supply cord is damaged, it must be replaced by the manufacturer, service agent, or similarly qualified person to avoid a hazard.

Failure to follow these instructions may result in severe injury or death from electrocution.



WARNING! DO NOT use a water jet to clean or rinse the machine. Failure to follow these instructions may result in serious electrical shock.



WARNING! Avoid injury.

- **DO NOT** allow untrained personnel to operate this machine.
- **DO NOT** operate the machine unless all service panels and access doors are fastened with screws.
- **DO NOT** remove any internal operating parts (including, but not limited to the freezer door, beater, or scraper blades) unless all control switches are in the OFF position.

Failure to follow these instructions may result in severe personal injury, especially to fingers or hands, from hazardous moving parts.



WARNING! This machine has many sharp edges that can cause severe injuries.

- **DO NOT** put objects or fingers in the door spout. This may contaminate the product and cause severe personal injury from blade contact.
- **USE EXTREME CAUTION** when removing the beater assembly. The scraper blades are very sharp.

Failure to follow these instructions can result in personal injury or damage to the machine.



IMPORTANT! Access to the service area of the machine must be restricted to persons having knowledge and practical experience with the machine, in particular as far as safety and hygiene are concerned.



CAUTION! This machine must be placed on a level surface. Use caution when moving the machine. Failure to comply may cause the machine to tip over and result in personal injury.



NOTICE! Cleaning and sanitizing schedules are governed by your federal, state, or local regulatory agencies and must be followed accordingly. Please refer to the cleaning section of this manual for the proper procedure to clean this machine.



CAUTION! This machine is designed to maintain product temperature under 41°F (5°C). Any product being added to this machine must be below 41°F (5°C). Failure to follow this instruction may result in health hazards and poor machine performance.

Do not obstruct air intake and discharge openings:

Counter Models: 6" (152 mm) minimum airspace on both sides. Place the rear of the machine against the wall to prevent recirculation of warm air.

Console Models: 3" (76 mm) minimum airspace on each side and rear of machine when air deflector is employed.

Failure to allow adequate clearance can reduce the refrigeration capacity of the freezer and possibly cause permanent damage to the compressor.

For Indoor Use Only: This machine is designed to operate indoors, under normal ambient temperatures of 70°F to 75°F (21°C to 24°C). The freezer has successfully performed in high ambient temperatures of 104°F (40°C) at reduced capacities.

Do not run the machine without product. Failure to follow this instruction can result in damage to the machine.

Noise Level: Airborne noise emission does not exceed 78 dB(A) when measured at a distance of 39 in. (1.0 m) from the surface of the machine and at a height of 63 in. (1.6 m) from the floor.

Model 60 Exploded View

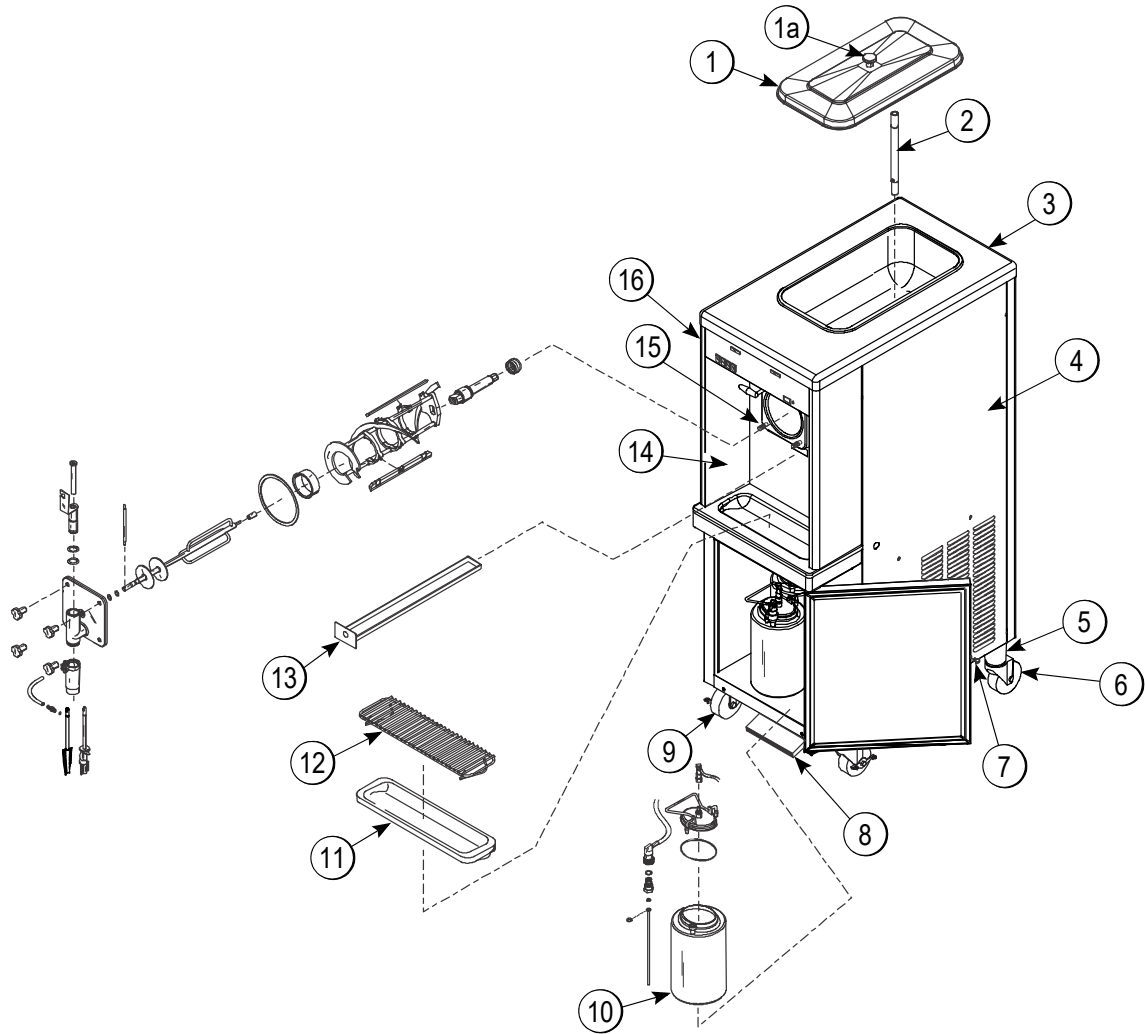

Figure 4-1

4

Item	Description	Part No.
1	Cover A.- Hopper- Std.	X38458- SER
1a	Knob-Mix Cover	025429
2	Tube- Feed- 1/4 Hole	015176-5
3	Panel- Rear w/Louvers	026980-SP
4	Panel-Side	067722
5	Adaptor A.- Caster	X18915
6	Caster- Swv 5/8 Stem 4" Wheel	034081
7	Screw- 1/4- 20 x 3/8 Rhm- Stnls	011694
8	Pedal A.- Foot	X48826

Item	Description	Part No.
9	Caster- 4" Swv 5/8 Stem w/Brake	034081
10	Tank- SYR- 4 Qt	045533
11	Tray- Drip 14.8	046275
12	Shield- Splash-Wire 13- 11/16 L	046177
13	Pan- Drip 19- 1/2 Long	035034
14	Panel A.- Front	X46634
15	Stud- Nose Cone 5/16- 18	011390
16	Panel - Side	067721

Model 62 Exploded View

4

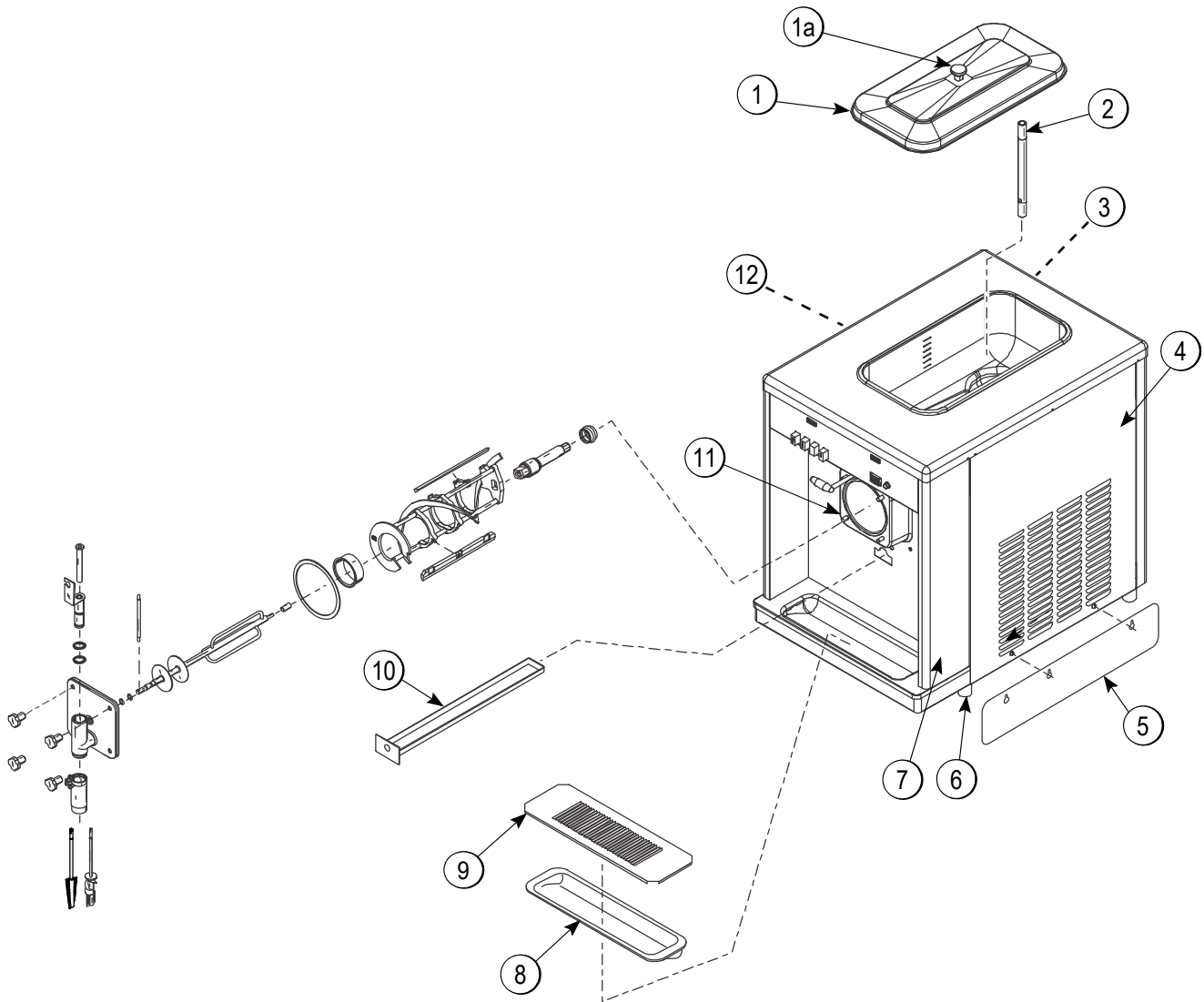

Figure 4-2

Item	Description	Part No.
1	Cover A.- Hopper- Std.	X38458- SER
1a	Knob-Mix Cover	025429
2	Tube- Feed- 1/4 Hole	015176-5
3	Panel-Rear	039021
4	Panel-Side-Right	085411
5	Skirt-Air Flow	049069
6	Leg-4" SS w/O-ring	013458

Item	Description	Part No.
7	Panel A.-Front	X49996-1
8	Tray-Drip 16-7/8 L x 5-1/8	020157
9	Shield-Splash	022765
10	Pan-Drip 19-1/2 Long	035034
11	Stud-Nose Cone 5/16-18 x 3/8-1	011390
12	Panel A.-Side Left	X85409

Door and Beater Assembly

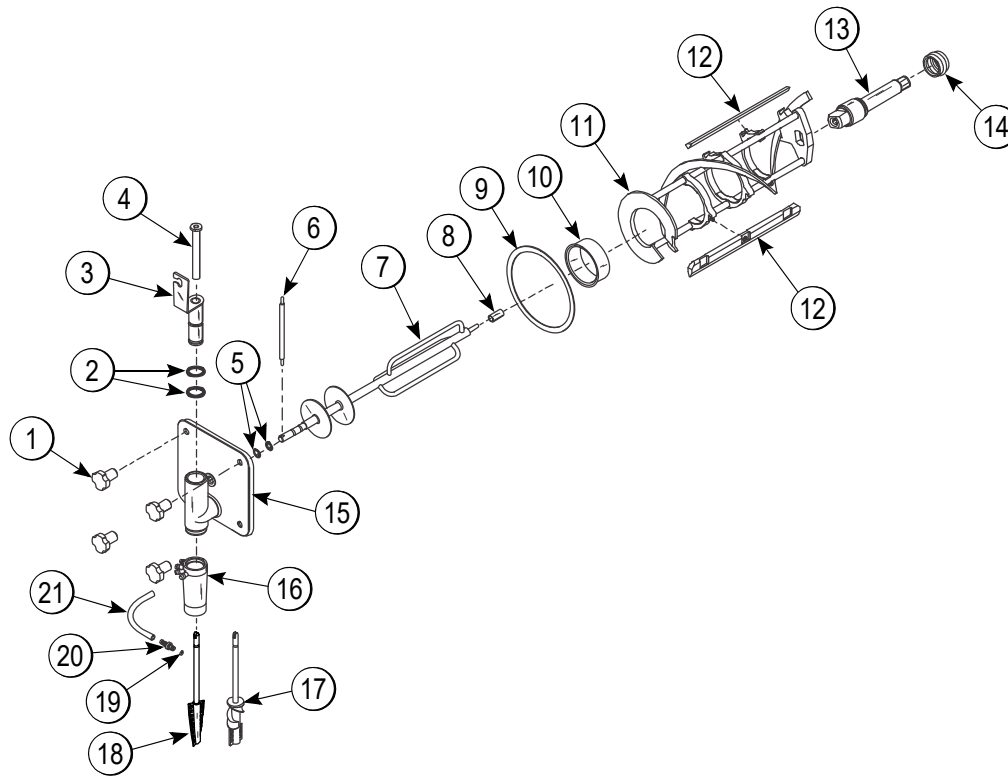

Figure 4-3

Item	Description	Part No.
1	Nut-Stud	021508
2	O-ring- 1- 1/16 OD X .139W	084545
3	Valve A.-Draw	X46671
4	Bearing-Spinner	017032
5	O-ring-.291 ID x .080W	018550
6	Arm-Torque	014500
7	Torque A.	X17381
8	Bearing-Guide	014496
9	Gasket-Door	016672
10	Bearing-Front	013116
11	Beater A.-7QT-1 Pin	X46233
12	Blade-Scraper-Plastic 9-13/16L	084950
13	Shaft-Beater	035527
14	Seal- Drive Shaft	032560
15	Door A.-Partial-1 SPT	X93448-SER

Item	Description	Part No.
16	Housing-Spinner *4 SPIG	017269
17	Blade A.-Spinner 8-3/8" (Not used in 006227CANH, 006233CANH, 006027CANH, 006033CANH, 0H6027CWMK and 0H6033CWMK)	X35570
18	Blade A.-Spinner (Used in 006227CANH, 006233CANH, 006027CANH, 006033CANH, 0H6027CWMK and 0H6033CWMK only)	X16961
19	O-ring-5/16 OD x .070W (Model 60)	016272
20	Fitting-QD Male Insert (Model 60)	036296
*21	Tube-Vinyl 3/16ID x 1/16 Wall (Model 60)	020940-6

Items 19, 20, 21, and 17 used on Model 60 only

*Bulk Part Number is R30314

**Not Shown

Accessories

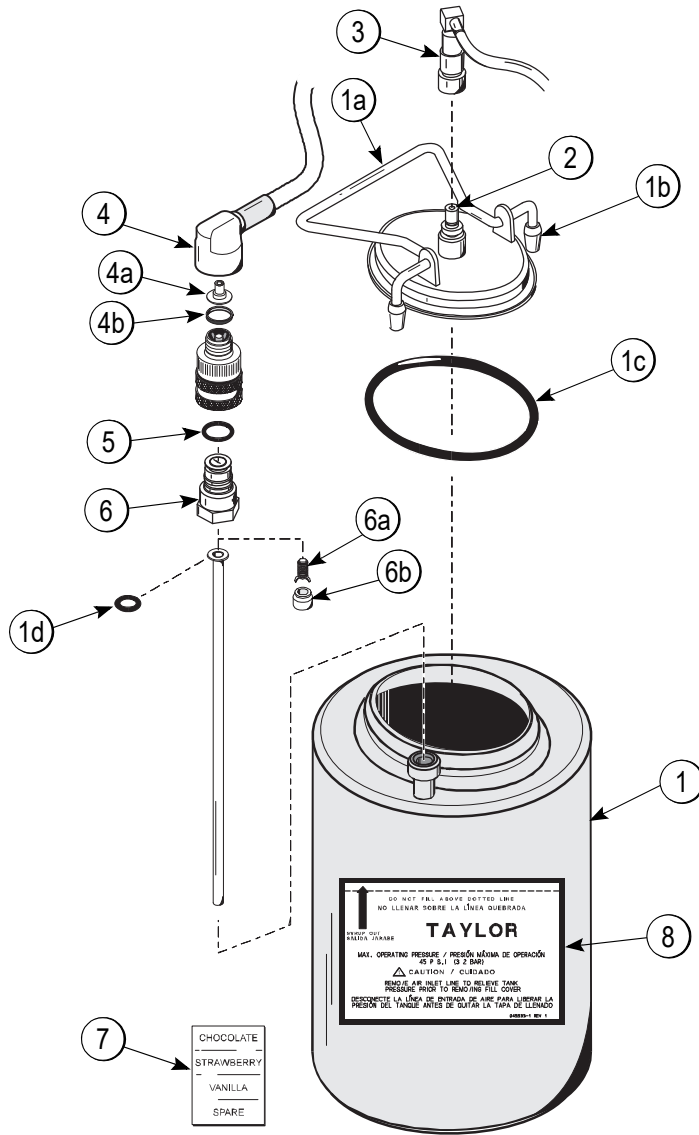

Figure 4-4

Item	Description	Part No.
1	Tank-SYR-4 Qt.	045533
1a	Cover-Tank 8 Qt. w/Inlet FTG.	035759-1
1b	Tip-Nylon-White Translucent	042747
1c	O-ring-3.437 ID x .275 W	016037
1d	O-ring-.291 ID x .080 W	018550
2	Plug-Q.D. CO2 1/8 MP	021077
3	Socket-Q.D. CO2 90 1/4 Barb	021524
4	Socket-Q.D. Liq.- 90 1/4 Barb	021026

Item	Description	Part No.
*4a	Restrictor-Syrup	025816
4b	Gasket-Rubber	023551
5	O-ring-5/8 OD x .103 W	016030
6	Plug-Q.D. Liq. 3/4-18 FP	021081
6a	Valve A.-Q.D. Plug	021081-2
6b	Insert	021081-1
7	Decal-Set 4 Syrup Flavor	021523
8	Decal-Syrup Tank Instruction	045533-1

*Not used on chocolate

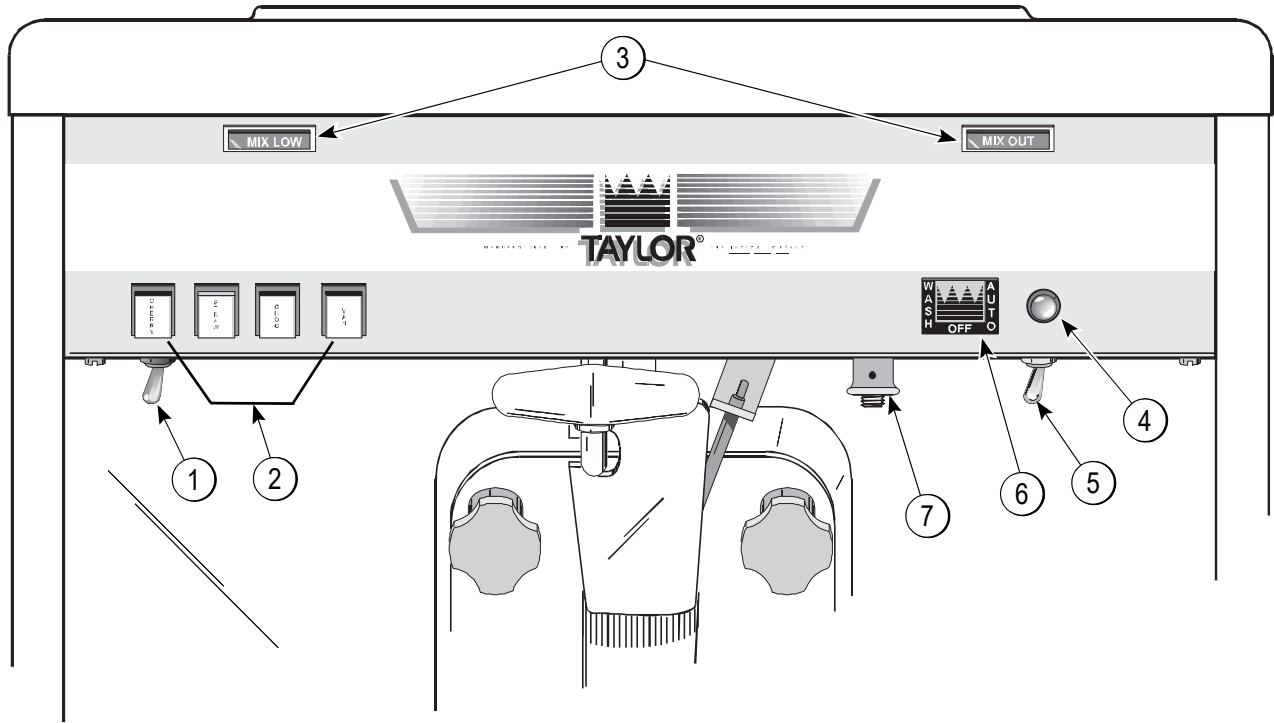

Figure 5-1

Item	Description
1	Auto Lift Switch
2	Flavor Selector Switches
3	Indicator Lights
4	Dial Light

Item	Description
5	Spinner Rinse Switch
6	Control Switch
7	Consistency Control (Switch- Torque)

Symbol Definitions

To better communicate in the international arena, many of our operator switches and buttons use symbols to indicate their functions. Your Taylor machine is designed with these international symbols.

The following chart identifies the symbol definitions:

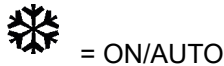

= ON/AUTO



= OFF



= MIX Button



= WASH



= MIX LOW



= MIX OUT



= HEAT MODE



= FILL Button



= RINSE Button

5

Control Switch

The center position is OFF. The left position is WASH, which activates the beater motor only. The right position is AUTO. It activates the beater motor and the refrigeration system. To activate the refrigeration system, raise the draw arm momentarily.

Dial Light

A red dial light is on the right side of the control switch. When the control switch is in the AUTO position, this light will come on, indicating that the refrigeration system is operable.

Indicator Light—MIX LOW

The MIX LOW indicator light is on the front of the machine directly above the flavor selector switch. When the light flashes, it indicates that the mix hopper has a low supply of mix and should be refilled as soon as possible. If mix is not added, a starved freezing cylinder will cause damage to the beater, blades, and driveshaft.

Indicator Light—MIX OUT

A MIX OUT indicator light is on the front of the machine directly above the control switch. When the light is on, the machine will shut down to prevent a starved freezing cylinder.

Reset Mechanism



CAUTION! DO NOT use metal objects to press the RESET button. Failure to follow this instruction may result in electrocution.

The reset protects the beater motor from overloading. If an overload occurs, the reset mechanism will trip. To properly reset the freezer, set the control switch to OFF. Lift up the right upper-side panel and press the RESET button firmly. Turn the control switch to WASH and observe the freezer's performance. Return the control switch to the AUTO position to resume normal operation.

If the reset mechanism should trip again, contact your Taylor distributor to resolve the problem.

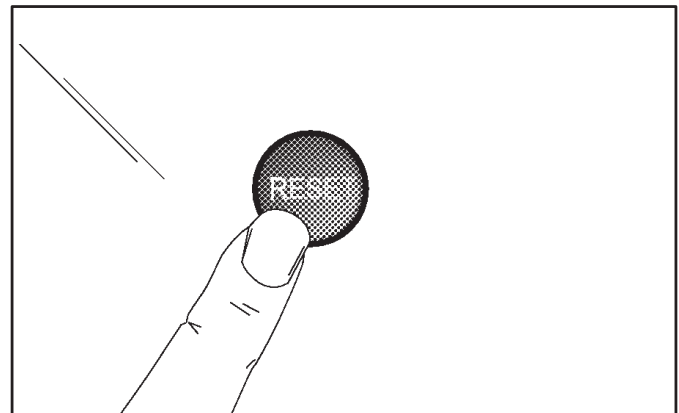

Figure 5-2

Consistency Control

The viscosity (thickness) of the shake is controlled by a sensing device called the consistency control. The consistency control knob is below the control switch. To achieve a thicker shake, turn the knob clockwise. For a thinner shake, turn the knob counterclockwise.

The refrigeration system must cycle on and off two or three times before an accurate consistency can be evaluated.

See Figure 5-1 on page 5-1.

Spinner Rinse Switch

The spinner rinse switch is next to the consistency control knob. To clean syrup residue from the spinner housing:

1. Place the control switch in the AUTO position.
2. Hold a cup under the spinner housing.
3. Press the spinner rinse switch. Water will flow until the switch is released.
4. Release the switch when the housing has been thoroughly rinsed.

See Figure 5-1 on page 5-1.

Auto Lift Switch (Model 60 Only)

The auto lift switch is below the flavor selector switch. The auto lift switch may be used to draw product. Press the switch. Just before the desired level in the cup is reached, release the switch. The draw arm will lower the draw valve and the product will stop flowing.

See Figure 5-1 on page 5-1.

Foot Pedal (Model 60 Only)

The foot pedal is on the lower front of the machine. The foot pedal may be used to draw product from the Model 60. Press the foot pedal. Just before the desired level in the cup is reached, release the foot pedal. The draw arm will lower the draw valve and the product will stop flowing.

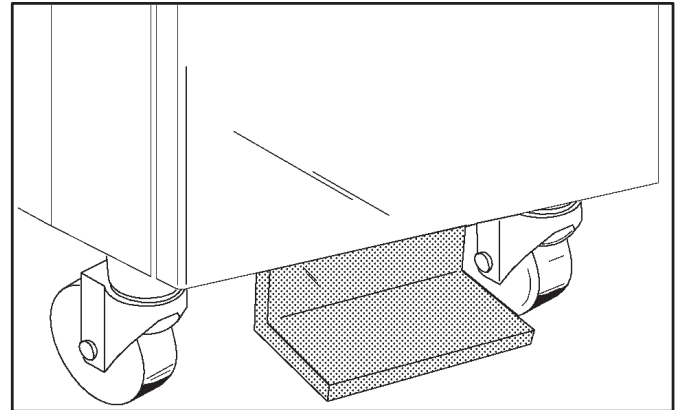

Figure 5-3

Flavor Selector Switch

The flavor selector switch consists of four flavor buttons. The left button (CHERRY) controls the No. 1 tank and its lines. The second button (STRAW) from the left controls the No. 2 tank and its lines. The third button (CHOC) from the left controls the No. 3 tank and its lines. The right selector button (VAN) is the Off button and may be used to dispense unflavored product as a vanilla shake.

See Figure 5-1 on page 5-1.

The Models 60 and 62 have one 7 quart (6.6 liter) freezing cylinder. These totally automatic freezers offer four separate flavors. Each flavor is blended and ejected from the same spout. (Use only single-strength syrup that is free of pulp and seeds.)

We begin our instructions at the point when we enter the store in the morning and find the parts disassembled and laid out to air-dry from the previous night's brush-cleaning.

These opening procedures will show you how to assemble these parts into the freezer, sanitize them, and prime the freezer with fresh mix in preparation to serve your first shake.

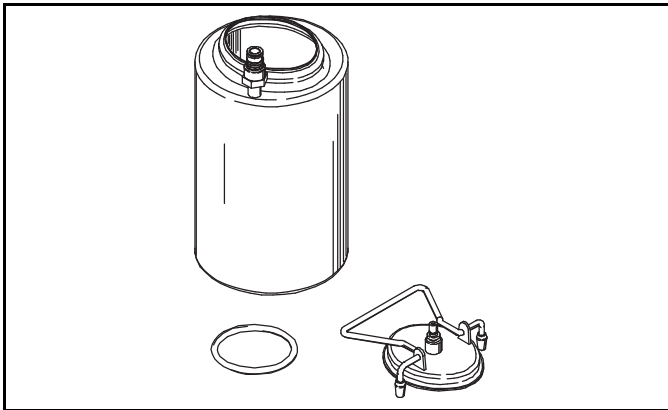

Figure 6-1

If you are disassembling the machine for the first time or need information to get to this point in the instructions, turn to Disassembly on page 6-13.

Assembly

Note: When lubricating parts, use an approved food grade lubricant (example: Taylor Lube).



WARNING! Make sure the power switch is in the OFF position before installing/removing any parts. Failure to follow this instruction may result in severe personal injury or electrocution.

Make sure your hands are sanitized before assembling the freezer.

1. Installing the driveshaft: Lubricate the groove and shaft portion of the beater driveshaft that comes in contact with the bearing on the beater driveshaft. Slide the driveshaft seal over the shaft and groove until it snaps into place. **Do not lubricate the hex end of the driveshaft.**

Fill the inside portion of the seal with 1/4 in. (6.35 mm) more lubricant. Lubricate the flat side of the seal that comes in contact with the bearing.

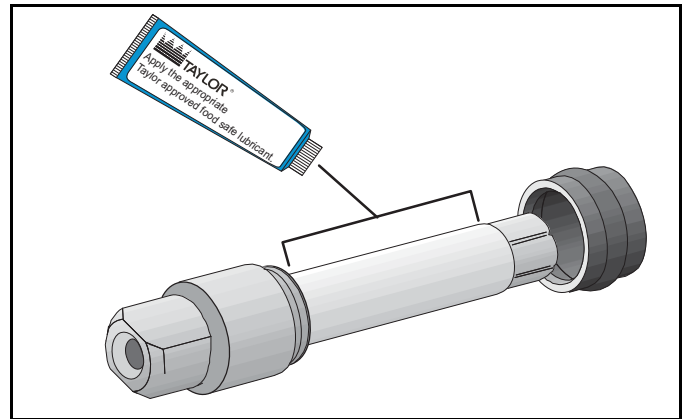

Figure 6-2

Note: Make sure the seal is not installed inside out. The ridge that protrudes at the center of the seal should be on the **outside**.

2. Install the driveshaft into the freezing cylinder, hex end first, and into the rear shell bearing until the seal fits securely over the rear shell bearing. Make sure the driveshaft fits into the drive coupling without binding.

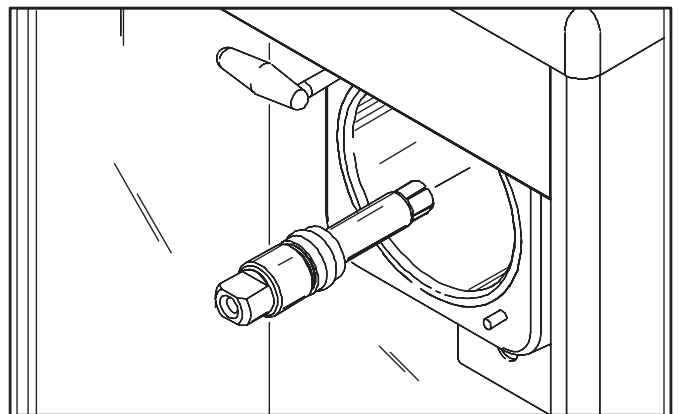

Figure 6-3

OPERATING PROCEDURES

Note: After inserting the driveshaft into the freezing cylinder, use a single-service paper towel to remove any excess lubricant that was displaced from the driveshaft seal when it was installed onto the rear shell bearing.

3. Before installing the beater assembly, inspect the scraper blades.

Check the scraper blades for any signs of wear or damage. If a scraper blade is nicked or worn, replace both blades.

If the blades are in good condition, place the rear scraper blade over the two rear holding pins (knife edge to the outside).

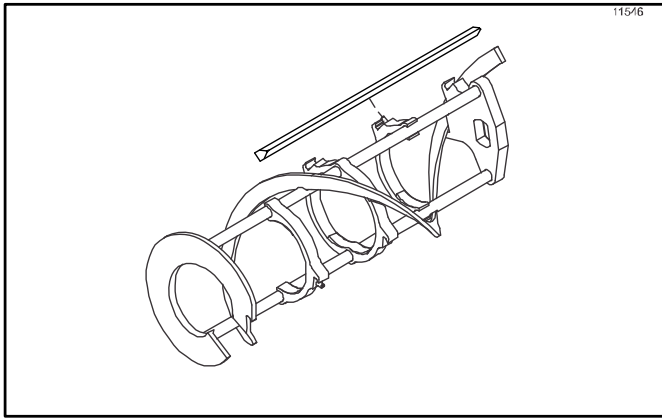

Figure 6-4

- 6 4. Holding the rear blade on the beater, slide it halfway into the freezing cylinder. Install the front scraper blade over the front holding pins. Slide the beater assembly the rest of the way into the freezing cylinder.

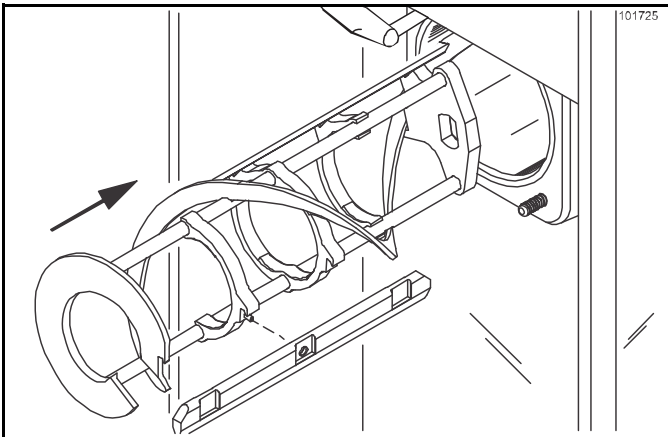

Figure 6-5

Make sure the beater assembly is in position over the driveshaft. Turn the beater slightly to make sure it is properly seated. When in position, the beater will not protrude beyond the front of the freezing cylinder.

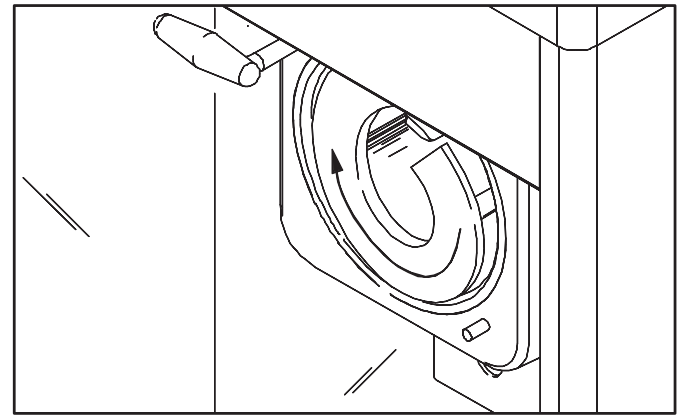

Figure 6-6

5. Install the torque rotor assembly. Assemble the torque rotor by sliding the two O-rings onto the front of the shaft. Lubricate them thoroughly to prevent leaking. Place the white plastic guide bearing on the rear of the rotor shaft. **Do not** lubricate the plastic guide bearing.

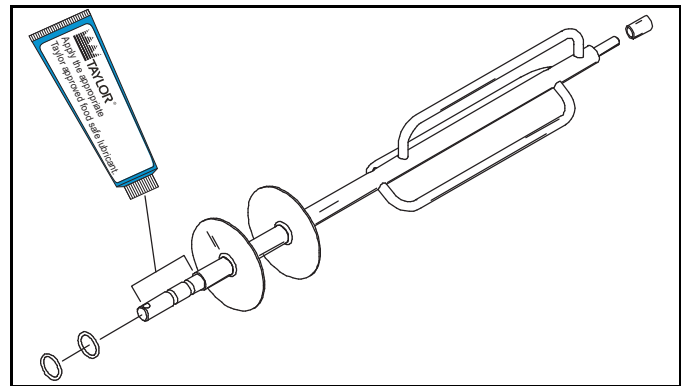

Figure 6-7

6. Insert the torque rotor, plastic guide bearing end first, **making sure** that it fits into the hole in the beater driveshaft. Rotate it several times to check for proper positioning.

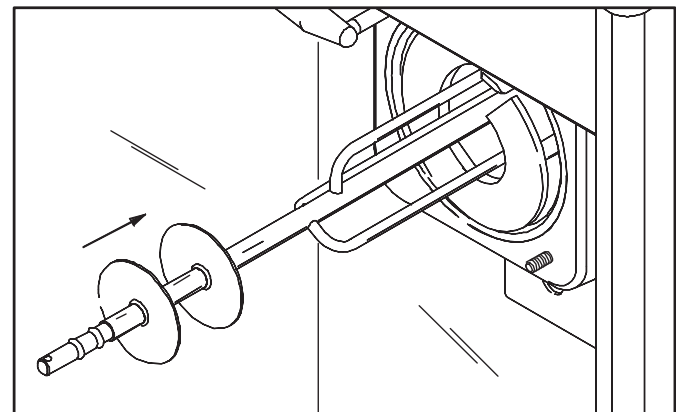

Figure 6-8

- 7. Before assembling the freezer door, check the following for any nicks, cracks, or signs of wear: door bearing, door gasket, draw valve, O-rings, and all sides of the door assembly, including the inside of the draw valve bore. Replace any damaged parts.
- 8. Install the draw valve. Lubricate the plastic spinner bearing. Insert the plastic spinner bearing into the top of the draw valve.

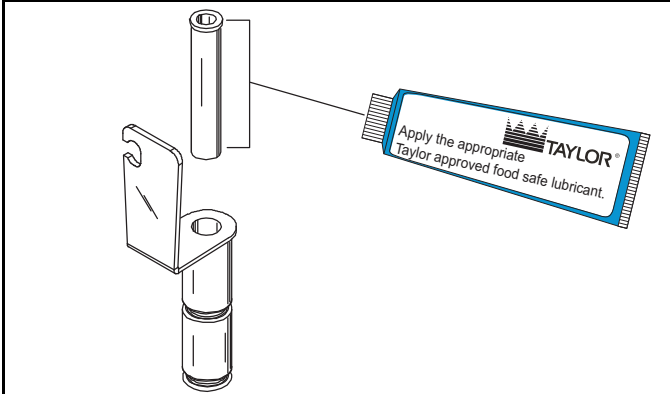

Figure 6-9

Slide the two O-rings onto the draw valve and lubricate.

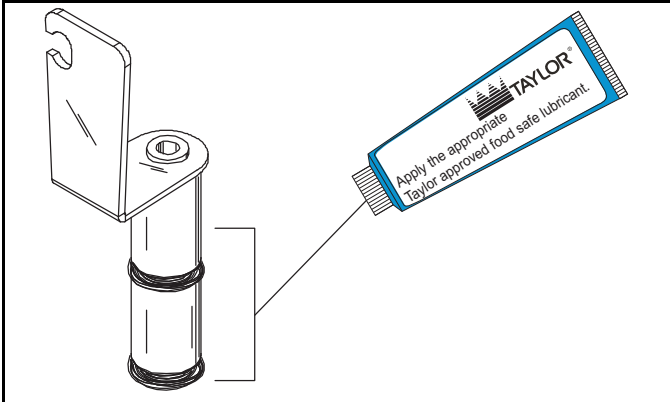

Figure 6-10

- 9. Lubricate the inside of the door spout, top and bottom. Insert the draw valve into the freezer door from the top. It will be necessary to rotate the draw valve bracket to the right to allow installation of the freezer door.

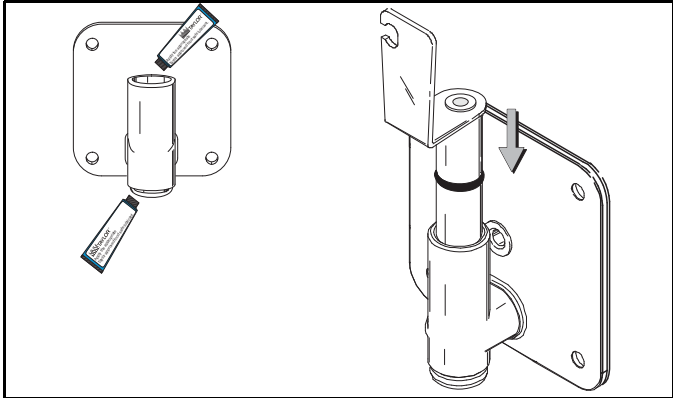

Figure 6-11

- 10. Place the large rubber gasket into the groove on the back side of the freezer door. **Do not** lubricate the gasket.

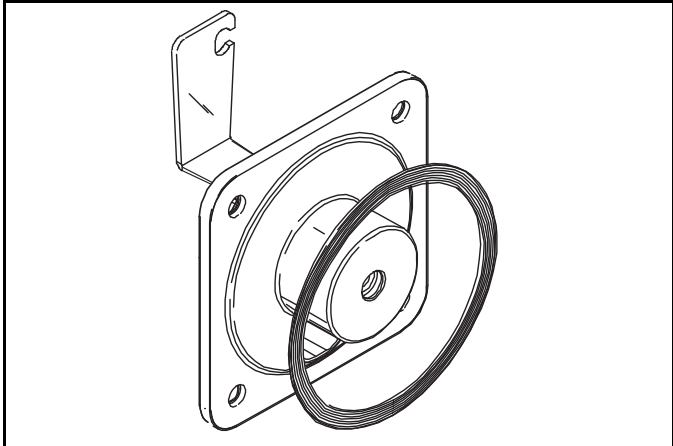

Figure 6-12

OPERATING PROCEDURES

Slide the white plastic front bearing onto the bearing hub. Make certain that the flanged end of the bearing is resting against the freezer door. **Do not** lubricate the front bearing.

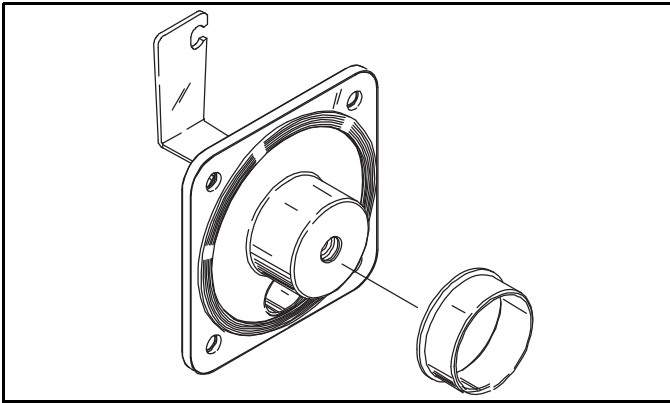

Figure 6-13

11. Install the freezer door. Locate the torque rotor in the center hole of the freezer door. Position the door on the four studs on the front of the freezing cylinder and firmly push it into place. Install the four handscrews on the studs and finger-tighten equally in a crisscross pattern to ensure the door is snug. **Do not** overtighten.

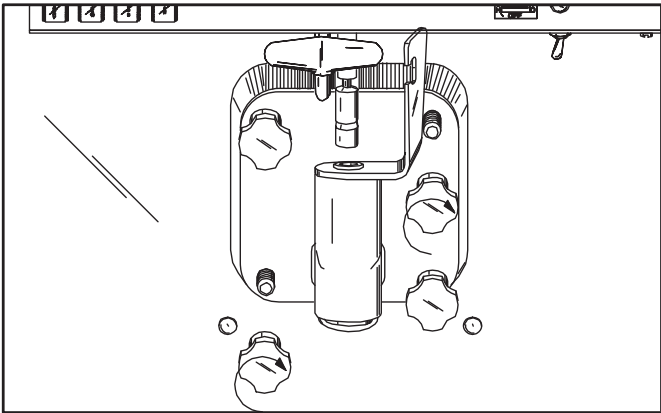

Figure 6-14

12. Install the drip pan into the hole in the front panel.

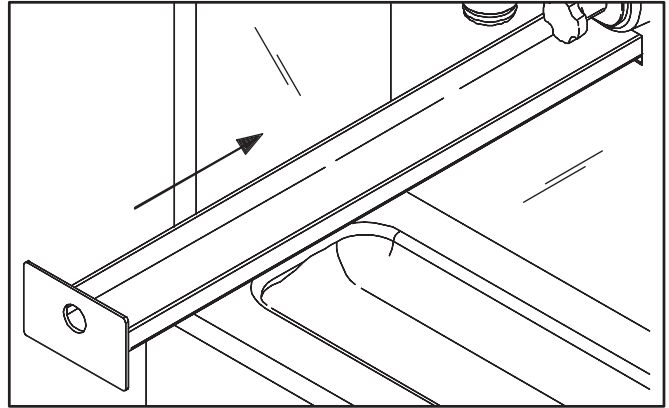

Figure 6-15

13. Install the spinner housing. Snap the plastic spinner housing onto the bottom of the door spout.

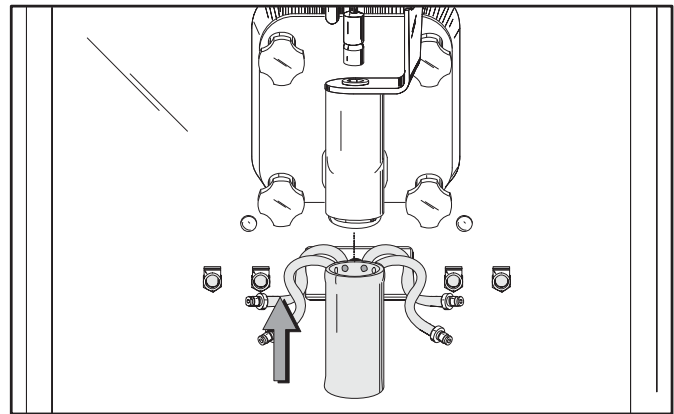

Figure 6-16

Lubricate the spinner blade shaft and insert the spinner blade from the bottom into the center of the draw valve.

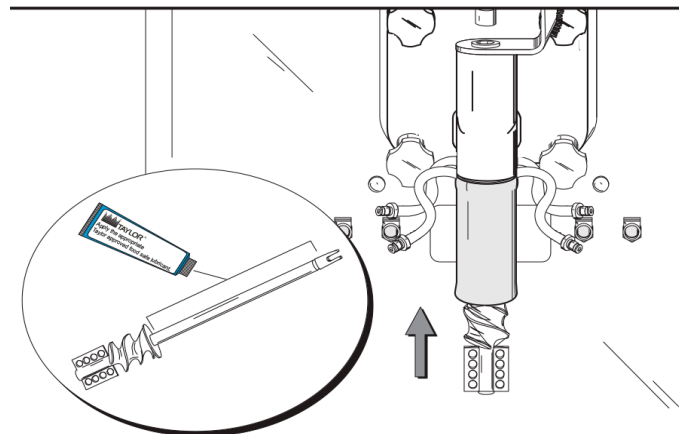

Figure 6-17

14. Locate the spinner coupling and slip it over the slotted end of the spinner blade shaft. Raise the slip collar on the coupling and turn the shaft from the bottom until the spinner coupling slips down into its locking position.

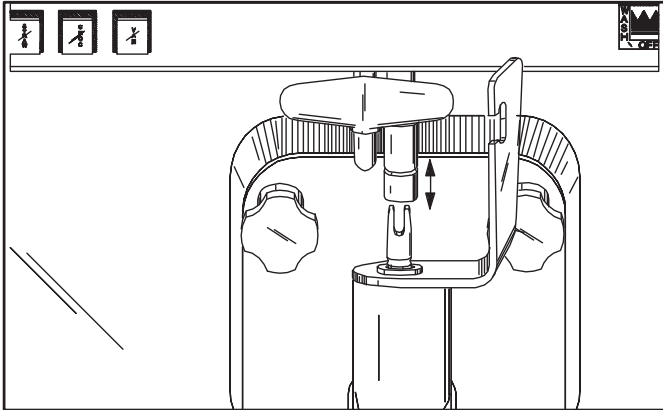

Figure 6-18

Rotate the draw valve to the left and center it on the draw arm. Place the draw arm into the slotted groove of the draw valve bracket.

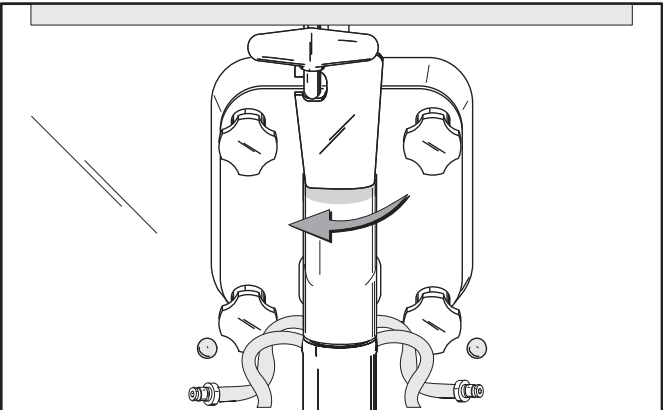

Figure 6-19

15. Install the torque arm. Position the torque arm by slipping it up through the slot in the operating arm. Then align the other end down in the hole in the torque rotor shaft, which protrudes from the door.

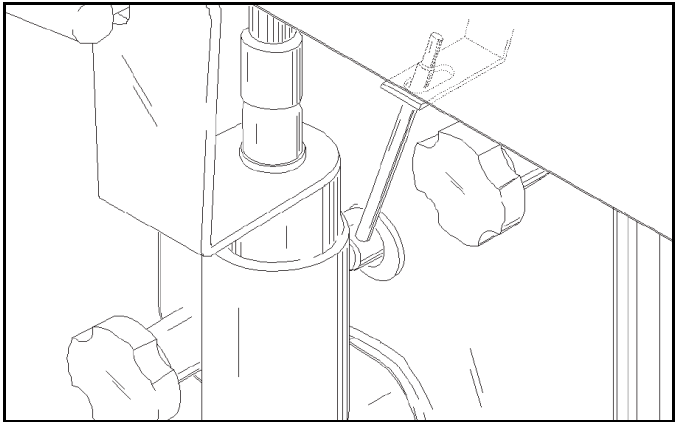

Figure 6-20

Check the torque arm by moving it back and forth to make sure it moves freely and easily.

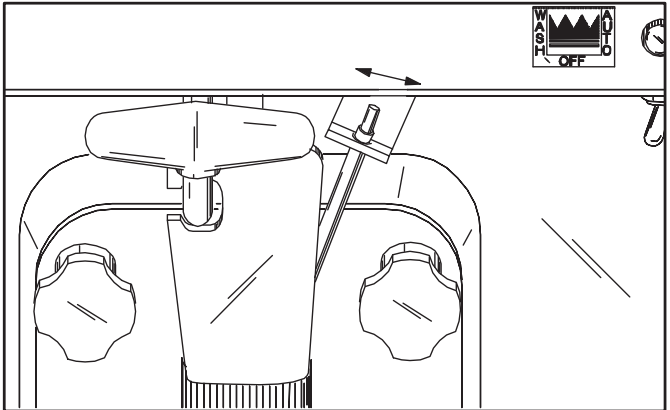

Figure 6-21

16. Connect the syrup lines. Connect the syrup lines of the spinner housing to the quick disconnect fittings on the front panel.

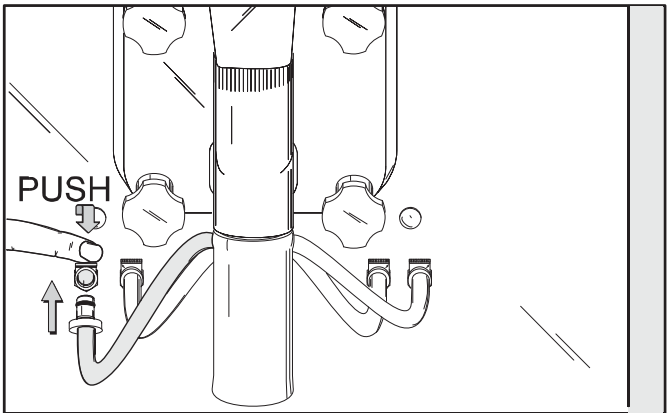

Figure 6-22

OPERATING PROCEDURES

17. Install the front drip tray and the splash shield.

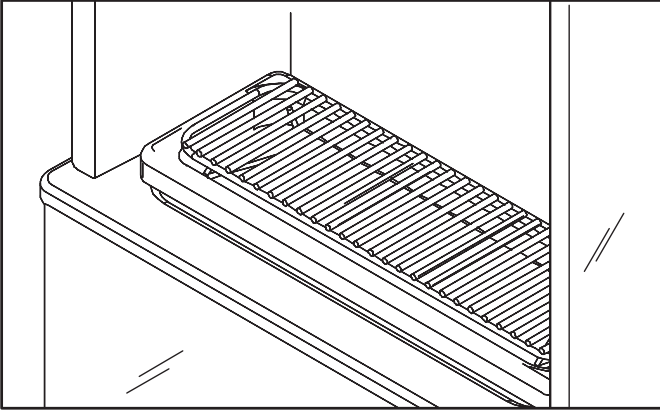

Figure 6-23

Sanitizing

1. Prepare a pail of an approved 100 ppm sanitizing solution (examples: 2-1/2 gal. [9.5 L] of Kay-5[®] or 2 gal. [7.6 L] of Stera-Sheen[®]). Use warm water and follow the manufacturer's specifications.

Note: Make sure your hands are clean and sanitized before continuing these instructions.

2. Lay the feed tube in the bottom of the mix hopper.

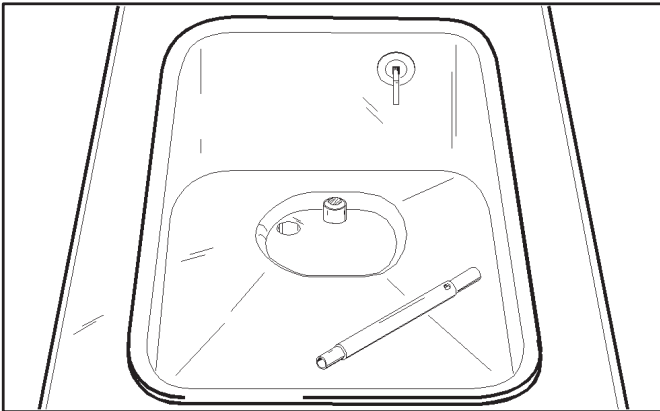

Figure 6-24

3. Pour the sanitizing solution into the mix hopper and allow it to flow into the freezing cylinder.

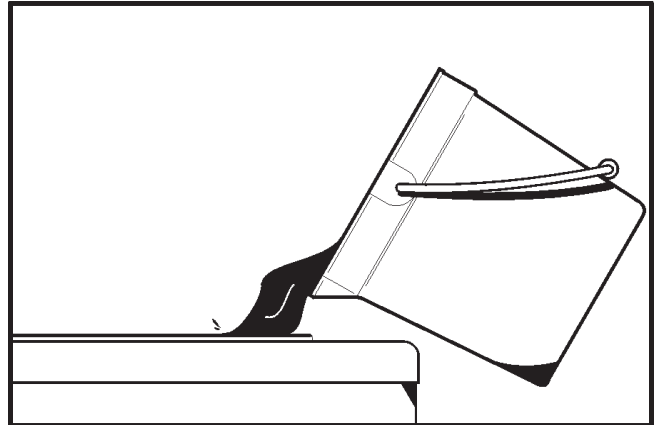

Figure 6-25

4. While the solution is flowing into the freezing cylinder, take particular care to brush-clean the mix hopper. While cleaning the mix hopper, make sure to brush the mix-level sensing probe on the rear wall of the hopper.



Figure 6-26

Brush-clean the mix inlet hole and the feed tube.

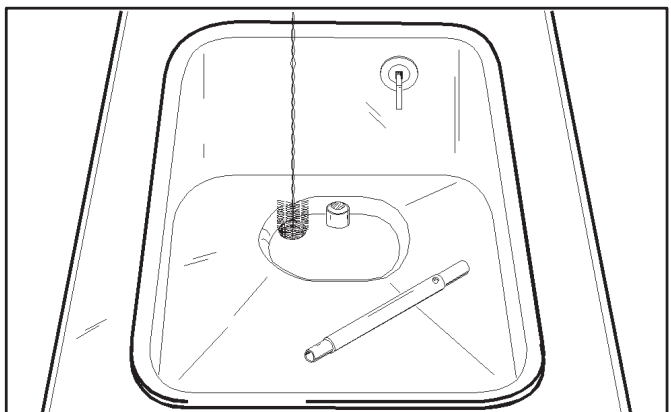

Figure 6-27

- Press the far right button on the syrup selector switch (VAN). Place the control switch in the WASH position. This will allow the solution to agitate in the freezing cylinder. Allow the solution to agitate for 5 minutes.

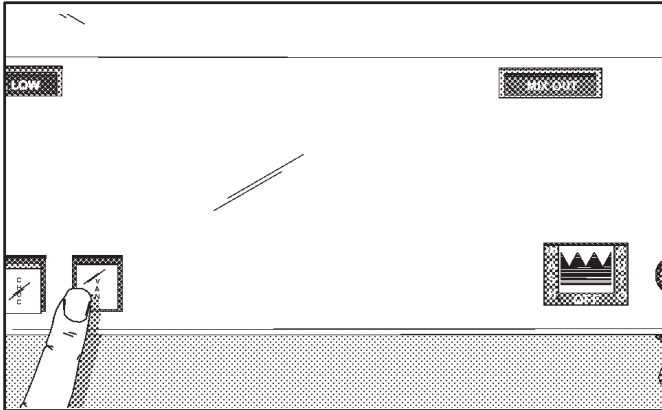

Figure 6-28

- Place an empty pail beneath the spinner housing and raise the draw arm. Draw off all the sanitizing solution. When the solution stops flowing from the spinner housing, lower the draw arm and place the control switch in the OFF position.

Important! The machine must **not** be placed in AUTO until all sanitizing solution has been removed from the freezing cylinder and proper priming procedures have been completed. Failure to follow this instruction may result in damage to the freezing cylinder.

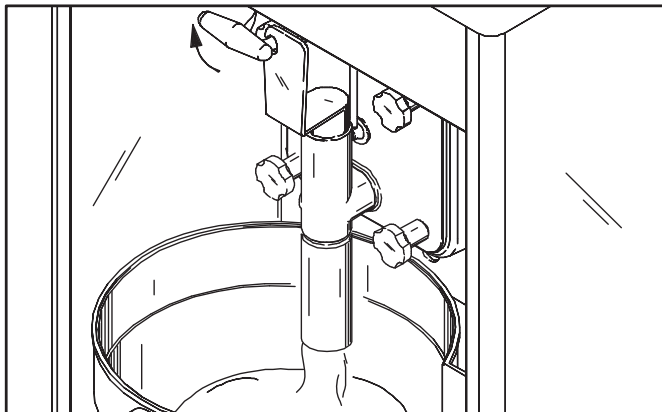

Figure 6-29

- Stand the feed tube in the corner of the mix hopper.

Priming

- Make sure the syrup selector switch is in the OFF position (VAN).

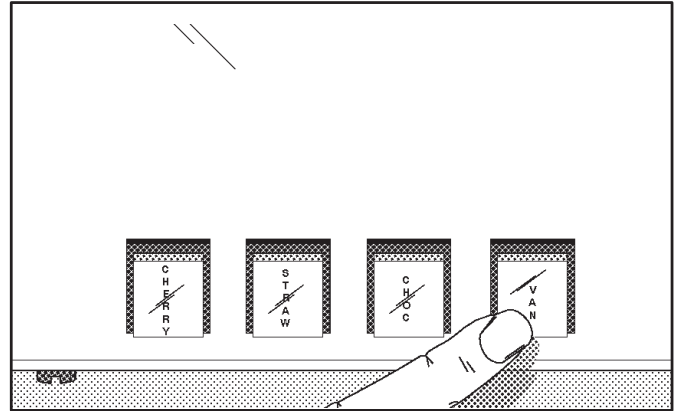

Figure 6-30

- With a pail beneath the spinner housing, raise the draw arm. Pour 2 gal. (7.6 L) of **fresh** mix into the mix hopper and allow it to flow down into the freezing cylinder. This will force out any sanitizing solution. When full-strength mix is flowing from the spinner housing, lower the draw arm. Discard the remaining sanitizing solution.

Important! Failure to remove all sanitizing solution may result in damage to the freezing cylinder.

When the mix has stopped bubbling down into the freezing cylinder, install the feed tube in the mix inlet hole. During AUTO operation, make sure the end of the feed tube with the hole in it is submerged in the mix.

6

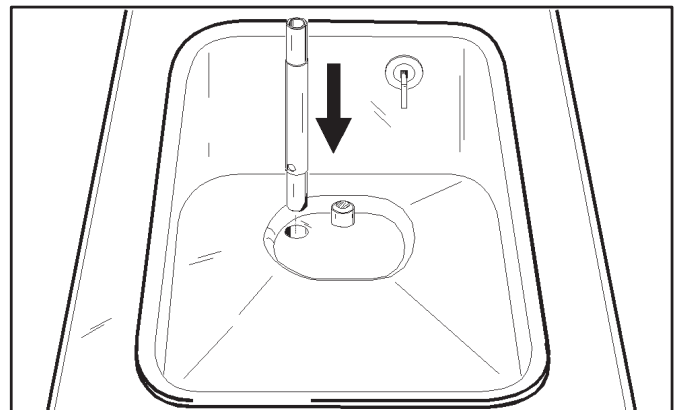

Figure 6-31

- Place the control switch in the AUTO position.

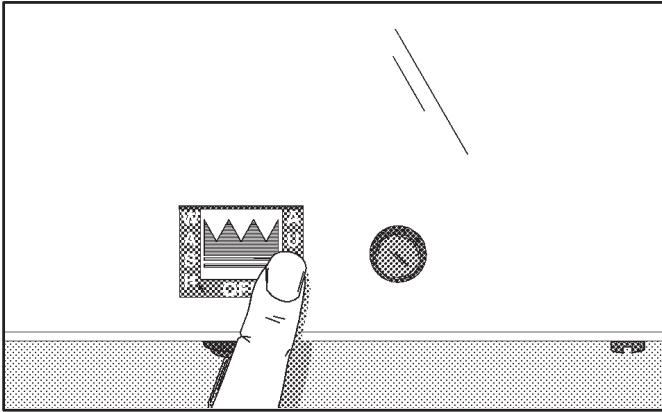

Figure 6-32

- To initiate freeze down, rotate the draw valve to the right so it is disengaged from the draw arm. Lift the draw arm momentarily. This will start the freezing cycle. Lower the draw arm and re-engage the draw valve. When the machine cycles off, the product is ready to serve.

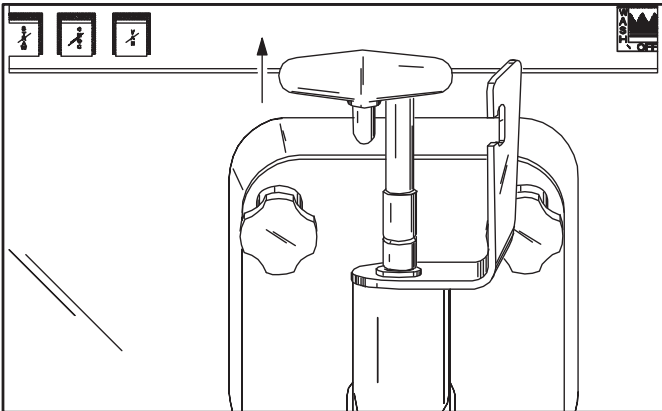

Figure 6-33

- Fill the mix hopper with mix. As the mix level comes in contact with the mix sensing probe on the rear wall of the hopper, the MIX LOW light will stop flashing.

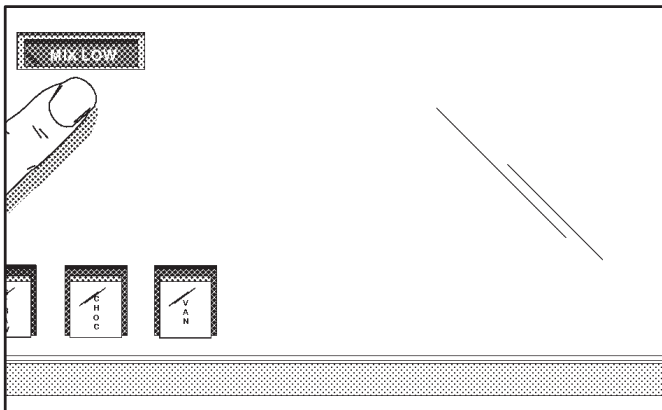

Figure 6-34

Place the mix hopper cover in position.

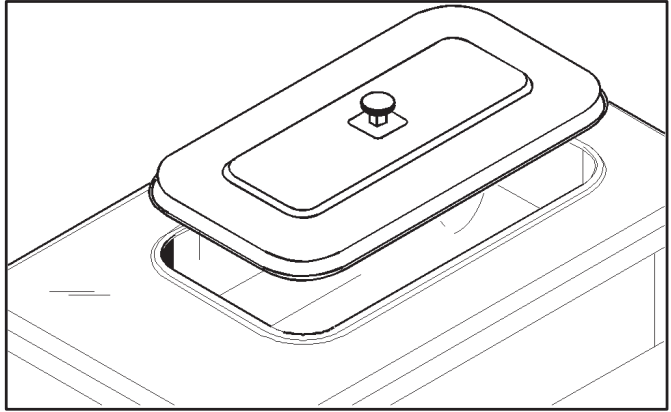

Figure 6-35

Syrup System

Two main objectives in the opening procedures are:

- Fill the syrup tanks.
- Calibrate the syrup flow.

The syrup system must be checked daily to ensure a high-quality shake.

Important! Use only single-strength syrup that is free of pulp and seeds.

Model 60

The syrup tanks are in the lower front syrup cabinet. The air lines and syrup lines are color spiral wrapped. Make sure to match the color-wrapped air and syrup line to the correct flavor syrup tank.

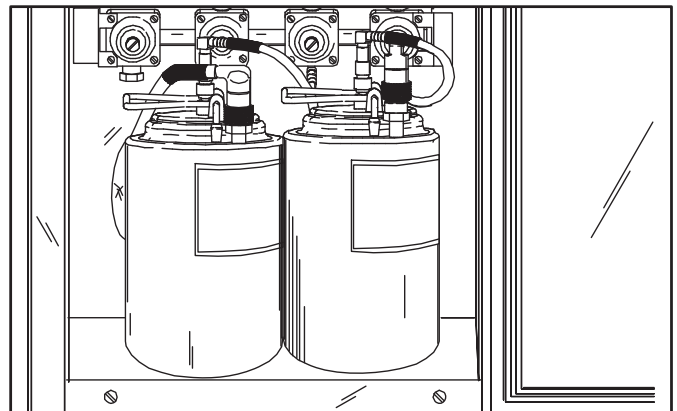

Figure 6-36

Model 62

The syrup tanks should be located within reach of the syrup lines. The air lines and syrup lines are color spiral wrapped. Make sure to match the color-wrapped air and syrup line to the correct flavor syrup tank. Compressed air or CO₂ may be used to propel the syrups.

1. **Filling the syrup tanks:** Pull back the collar of the quick disconnect fittings for the air lines. Allow the air pressure to dissipate from the syrup tanks. Disconnect the syrup lines.

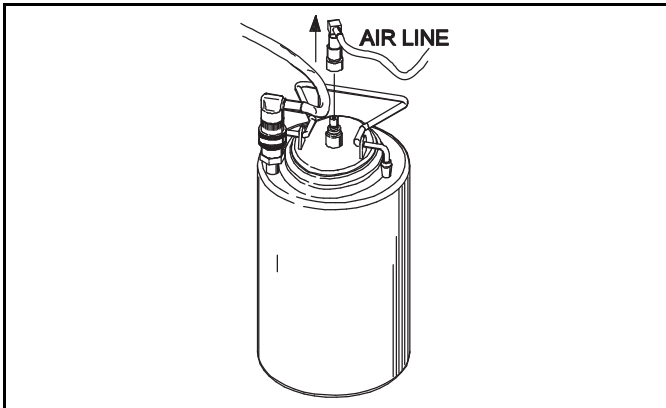

Figure 6-37

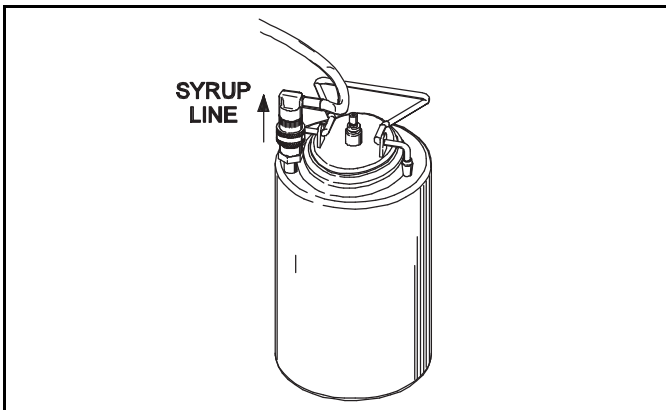

Figure 6-38

Remove the syrup tank lid by lifting up on the locking lever. Fill the syrup to the indicating mark on the label.

Important! Do not overfill the tanks.

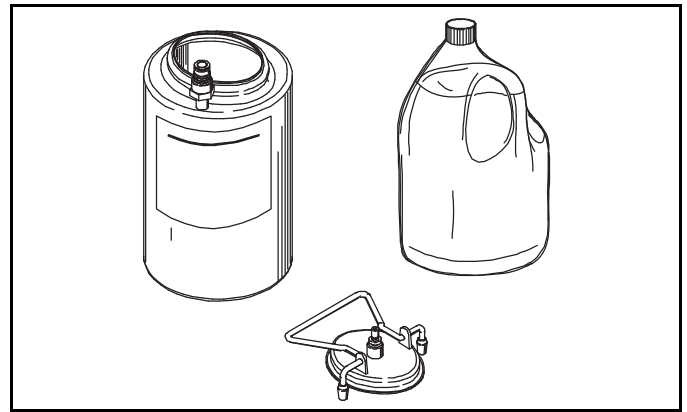

Figure 6-39

Install the tank lid. Match the spiral wrapped air and syrup lines to the syrup tank and connect them accordingly.

Note: See page 26 for cleaning and sanitizing the syrup tanks.

2. **Calibrating the syrup flow:** It is vital that the correct amount of syrup is incorporated into the mix to obtain a quality shake. Too much syrup often causes thin shakes. Too little syrup often causes thick shakes. To determine the rate of syrup flow, use a calibrating cup indicating the ounces of liquid. Generally the proper rate of syrup flow is 1 oz. (29.6 ml) of syrup in 6 seconds. Once this rate is set, the correct amount of syrup will be blended with the shake base regardless of the size of shake served.

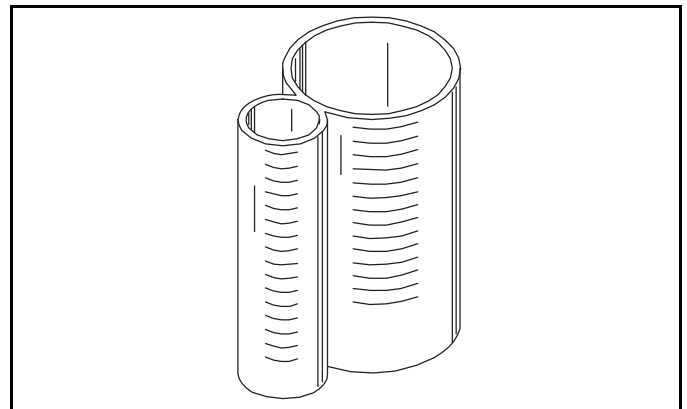

Figure 6-40

OPERATING PROCEDURES

Rest the draw arm on top of the draw valve. Place the control switch in the WASH position. Hold an empty cup under the spinner housing and, from the left, press the first flavor button. Purge this syrup line until pure syrup begins to flow steadily.

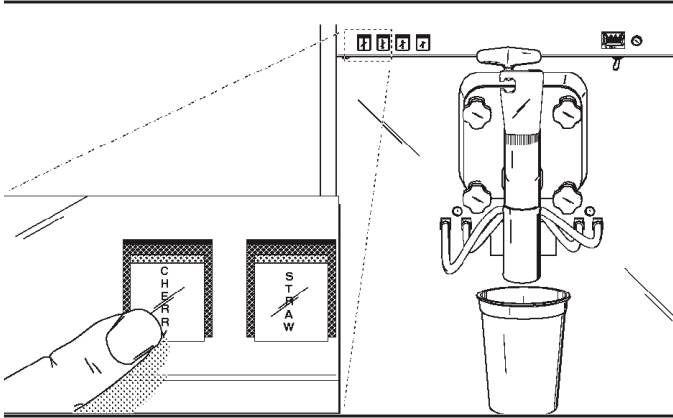

Figure 6-41

Note: It is very important to remove any sanitizing solution and/or air from the syrup lines for accurate calibration.

When pure syrup is flowing steadily from the spinner housing, press the far right button (VAN) to stop the syrup flow.

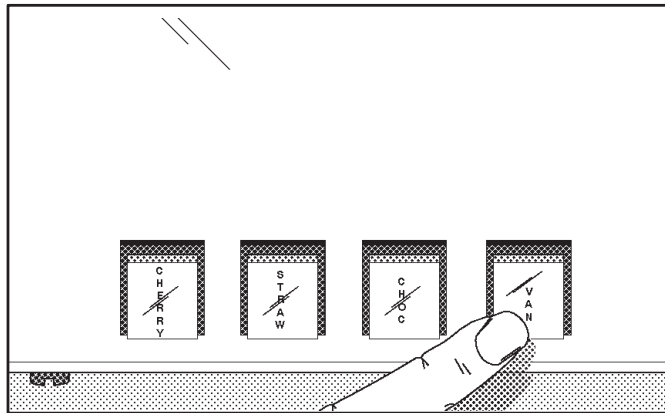

Figure 6-42

Position the large section of the calibrating cup under the spinner housing.

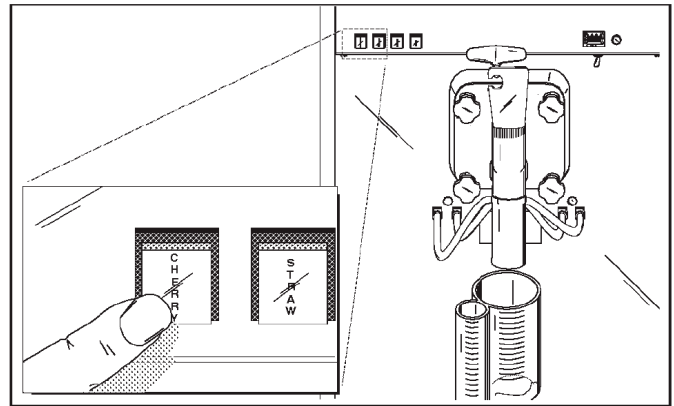

Figure 6-43

With a timing device, press the first flavor button catching the syrup in the calibrating cup. When the timing device reaches 6 seconds, press the far right button (VAN) to stop the syrup flow. If the amount of syrup received is 1 oz. (29.6 ml), the syrup is properly calibrated.

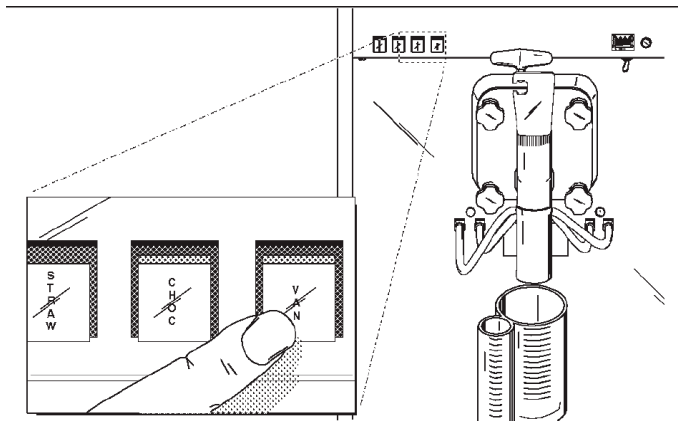

Figure 6-44

- 3. Adjusting the syrup pressure:** If the amount of syrup received is less than 1 oz. (29.6 ml), the syrup pressure must be increased. If the amount received is more than 1 oz. (29.6 ml), the pressure must be decreased.

Model 60

Inside the syrup compartment is an air pressure manifold with individual regulators to control the amount of pressure to each tank and syrup line. The left regulator is used for syrup line number 1 and so on.

Model 62

To make these pressure adjustments, use the pressure regulators supplied with your freezer. The left regulator is used for syrup line number 1 and so on.

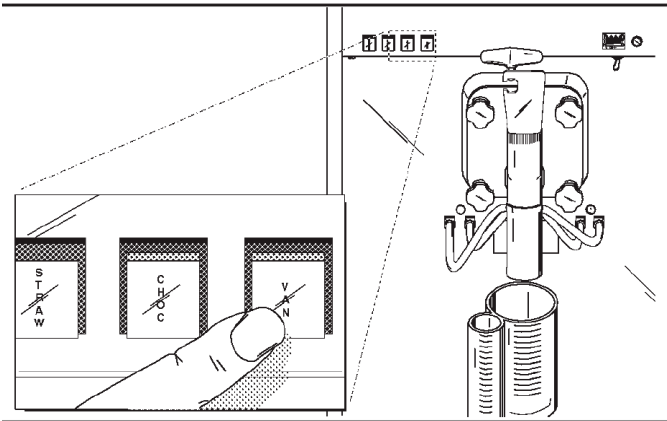

Figure 6-45

If less than 1 oz. (29.6 ml) is received, the pressure must be increased. Loosen the locknut. Using a flatblade screwdriver, turn the adjusting screw **clockwise**.

Recheck the syrup calibration. Tighten the locknut after the correct calibration is achieved.

If more than 1 oz. (29.6 ml) of syrup is received, the pressure must be decreased. Loosen the locknut and turn the adjusting screw **counterclockwise** to zero. Remove the air line to the syrup tank to allow the pressure in the tank to escape. Reconnect the air line. Adjust the regulator to the new pressure setting and recheck the syrup calibration. Tighten the locknut.

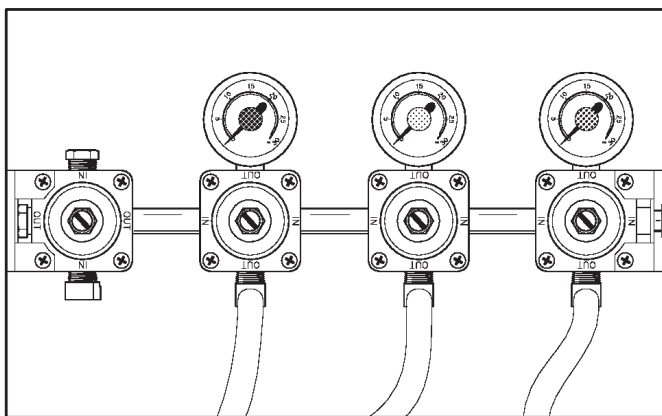

Figure 6-46

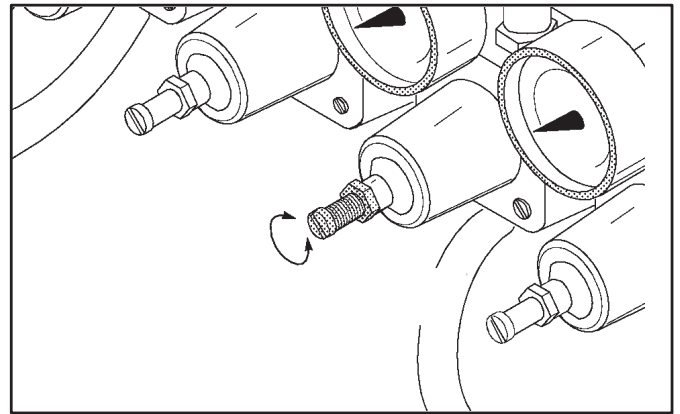

Figure 6-47

Repeat the calibration procedures for each additional syrup line.

Note: See page 6-14 for cleaning and sanitizing syrup lines.

Drawing Product

1. Prepare to draw product by holding a cup under the spinner housing. Press a desired flavor selection button.
2. **Model 60:** To draw product, push the auto lift toggle switch or press the foot pedal. This will cause the:
 - a. Draw arm to lift the draw valve to the open position.
 - b. Beater and spinner to start, and the solenoid valve (if flavor is used) to open.
 - c. A constant amount of flavor is blended into the product as it flows out of the freezer.

Release the auto lift toggle switch or the foot pedal just before the desired level in the cup is reached. The draw arm will lower the draw valve and the product will stop flowing.

Important! The Model 60 incorporates an auto lift system. This system may be activated by either a hand switch or foot pedal. Drawing product may also be accomplished by lifting the draw arm.

Model 62: To draw product, raise the draw handle fully. This will cause the:

- a. Beater and spinner to start, and the solenoid valve (if flavor is used) to open.
- b. A constant amount of flavor is blended into the product as it flows out of the freezer.

Lower the draw handle and the product will stop flowing.

Closing Procedures

To disassemble this machine, the following items will be needed:

- Two cleaning pails
- Sanitized stainless-steel rerun can with lid
- Cleaning brushes (provided with freezer)
- Cleaner/sanitizer
- Single-service towels

Draining Product From the Freezing Cylinder

1. Place the control switch in the OFF position as far ahead of cleaning time as possible to allow the frozen product to soften for easier cleaning.
2. Press the far right button on the selector switch assembly (VAN).
3. Remove the spinner blade by lifting the slip collar on the spinner coupling. Pull the spinner blade out from the bottom of the spinner housing.
4. Remove the mix hopper cover and feed tube from the mix hopper. Take these parts to the sink for cleaning.
5. If local health codes permit the use of rerun, place a sanitized, NSF-approved stainless-steel rerun container beneath the spinner housing, and place the control switch in the WASH position.

Model 60: Drain all the product remaining in the freezing cylinder and mix hopper by pressing the auto lift toggle switch or pressing the foot pedal. When the flow of product stops, release the auto lift toggle switch or foot pedal. Place the control switch in the OFF position.

Model 62: Drain all the product remaining in the freezing cylinder and mix hopper by raising the draw handle. When the flow of product stops, release the draw handle. Place the control switch in the OFF position.

Place a sanitized lid on the rerun container and put it in the walk-in cooler. (Note: For additional information regarding the proper use of rerun, see item 5 on page 7-1.)

Note: *If local health codes do not permit the use of rerun, the product must be discarded. Follow the instructions in step 5, except drain the product into a pail and properly discard the mix.*



ALWAYS FOLLOW LOCAL HEALTH CODES.

Rinsing

1. Pour 2 gal. (7.6 L) of cool, clean water into the mix hopper. With the brushes provided, scrub the mix hopper, mix-level sensing probes, the outside of the agitator housing, and the mix inlet hole.
2. Press the far right switch on the selector switch assembly (VAN). Place the control switch in the WASH position.
3. **Model 60:** With an empty pail under the spinner housing, push the auto lift toggle switch or press the foot pedal and drain off all the rinse water. When the flow of rinse water stops, release the auto lift toggle switch or foot pedal.
Model 62: With an empty pail under the spinner housing, raise the draw handle and drain off all the rinse water. When the flow of rinse water stops, release the draw handle. Place the control switch in the OFF position.
4. Repeat this procedure until the rinse water being discharged is **clear**.

Cleaning

1. Prepare a pail of an approved 100 ppm cleaning solution (examples: 2-1/2 gal. [9.5 L] of Kay-5[®] or 2 gal. [7.6 L] of Stera-Sheen[®]). Use warm water and follow the manufacturer's specifications.
2. Pour the cleaning solution into the hopper and allow it to flow into the freezing cylinder.
3. While the solution is flowing into the freezing cylinder, brush-clean the mix hopper, mix-level sensing probes, the outside of the agitator housing, and the mix inlet hole.
4. Place the control switch in the WASH position. This will cause the cleaning solution in the freezing cylinder to be agitated.
5. Place an empty pail beneath the spinner housing. Make sure the far right button (VAN) on the selector switch assembly is pressed.
6. **Model 60:** Press the auto lift toggle switch or press the foot pedal and drain off all the solution. When the flow of solution stops, release the auto lift toggle switch or foot pedal.

Model 62: Raise the draw handle and drain off all the solution. When the flow of solution stops, release the draw handle.

Place the control switch in the OFF position. Take the pail to the sink and discard the solution.

Disassembly



WARNING! Make sure the power switch is in the OFF position. Failure to follow this instruction may result in severe personal injury from hazardous moving parts.

1. Remove the torque arm. Separate the spinner housing from the freezer door.
Note: Pull the spinner housing toward you.
2. Disengage the draw arm from the draw valve and rotate the draw valve to the right.
3. Remove the freezer door, door gasket, front bearing, torque rotor assembly, beater, scraper blades, and driveshaft and seal from the freezing cylinder.

Note: When removing the door, take extreme care to separate the torque rotor shaft from the door. Damage will result if these parts are dropped during disassembly.

Take all these parts to the sink for cleaning.

If the guide bearing is not on the end of the torque rotor shaft, it is still lodged in the beater driveshaft. To remove, insert the torque arm into the side hole of the driveshaft and push the bearing forward.

4. Take the front drip tray and the splash shield to the sink for cleaning.
5. Remove the rear drip pan from the front panel.

Note: If the drip pan is filled with an excessive amount of mix, it is an indication that the driveshaft seal should be replaced or that it was improperly lubricated.

Brush-Cleaning

1. Prepare a sink with an approved 100 ppm cleaning solution (examples: Kay-5[®] or Stera-Sheen[®]). Use warm water and follow the manufacturer's specifications. If an approved cleaner other than Kay-5[®] or Stera-Sheen[®] is used, dilute according to label instructions.

Important! Follow label directions. Too **strong** of a solution can cause parts damage, and too **mild** of a solution will not provide adequate cleaning. Make sure all brushes provided with the freezer are available for brush-cleaning.

2. Remove the draw valve from the freezer door. Remove the spinner bearing from the draw valve. Remove all O-rings from the draw valve and torque rotor assembly. Remove the seal from the driveshaft. Remove the feed tube from the hopper.

Note: To remove O-ring, use a single-service towel to grasp the O-ring. Apply pressure upward until the O-ring pops out of its groove. With the other hand, push the top of the O-ring forward. It will roll out of the groove and can be easily removed. If there is more than one O-ring to be removed, always remove the rear O-ring first. This will allow the O-ring to slide over the forward rings without falling into the open grooves.

OPERATING PROCEDURES

3. Thoroughly brush-clean all disassembled parts in the cleaning solution, making sure all lubricant and mix film is removed. Take particular care to brush-clean the draw valve core and the holes in the freezer door.
4. Place the cleaned parts on a clean, dry surface to air-dry overnight.
5. Take a small amount of cleaning solution to the freezer. With the black bristle brush, brush-clean the rear shell bearing at the back of the freezing cylinder.

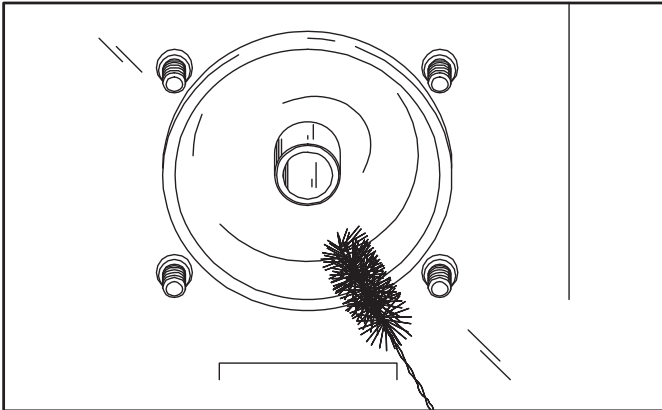

Figure 6-48

6. Wipe clean all exterior surfaces of the freezer.

Sanitizing Syrup System

6

Two main objectives in your closing procedures:

- Discard all syrup at least once a week.
- Flush the syrup lines at least once a week. This must be done on a regular basis to keep a buildup of old syrup from clogging the lines, and to break the bacteria chain, which develops in the tanks and lines.

Important! Calibrating the syrup flow must be done every morning, especially after flushing the syrup lines. Use only single-strength syrup that is free of pulp and seeds.

1. **Sanitizing syrup tanks:** Pull back on the collar of the quickconnect fitting of the air line. Allow the air pressure to dissipate from the syrup tank. Disconnect the syrup line.

Remove the syrup tank from its compartment. Remove the syrup tank lid by lifting up on the locking lever, and discard the remaining syrup.

Rinse the syrup tank with clean, warm water. Prepare 1/2 gal. (1.9 L) of the recommended sanitizing solution with warm water in the syrup tank. Brush-clean the inside and outside of the tank.

Using an adjustable wrench, remove the syrup line fitting from each tank. Remove the dip tube and O-ring from the syrup tank.

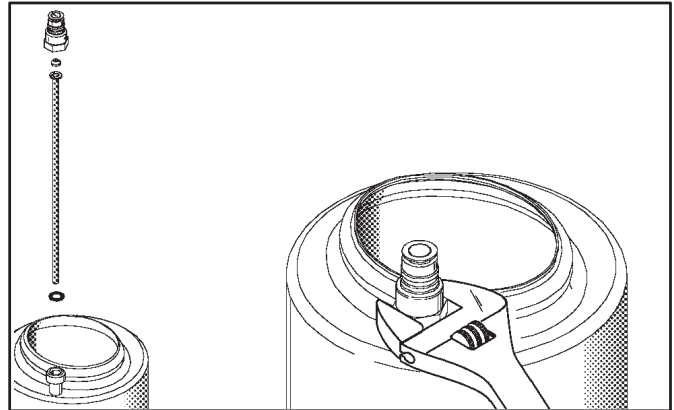

Figure 6-49

Thoroughly brush-clean the dip tube, syrup line fitting, and O-ring, using the sanitizing solution. Re-assemble dip tube, O-ring, and syrup line fitting. Pour out all the sanitizing solution and place the tank in an upside down position on a clean, dry surface to air-dry.

Repeat this procedure for all syrup tanks.

2. **Sanitizing syrup lines:** Prepare 1 gal. (3.8 L) of the recommended sanitizing solution with warm water in the spare syrup tank. Replace and lock the tank lid into position. Place this tank in the syrup compartment.
3. Remove syrup lines from the spinner housing. Wash and sanitize the spinner housing.

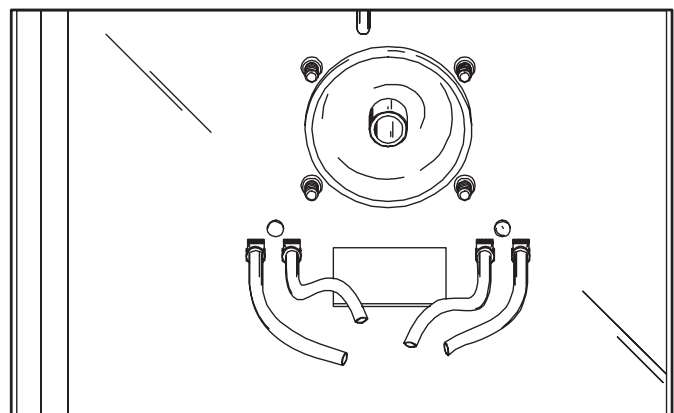

Figure 6-50

4. Install the freezer door and the draw valve on the freezer. Raise the draw arm and rest the arm on the top of the draw valve.

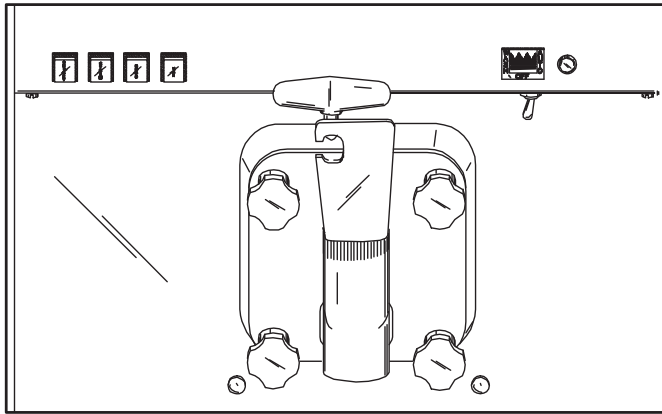

Figure 6-51

5. Press the far right button on the selector switch assembly (VAN) and place the control switch in the WASH position. This will partially close the electrical circuit so the syrup lines can be flushed by merely pressing the flavor buttons.
6. Connect the No. 1 air pressure line and syrup line to the tank filled with sanitizing solution.

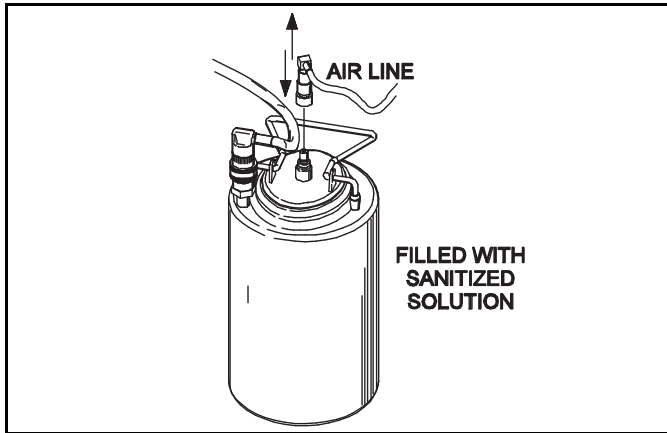

Figure 6-52

7. Place an empty pail beneath the ends of the syrup lines. Press the left flavor button and flush the No. 1 syrup line until the solution runs clear. Press the far right button (VAN) to stop the flow of sanitizing solution.

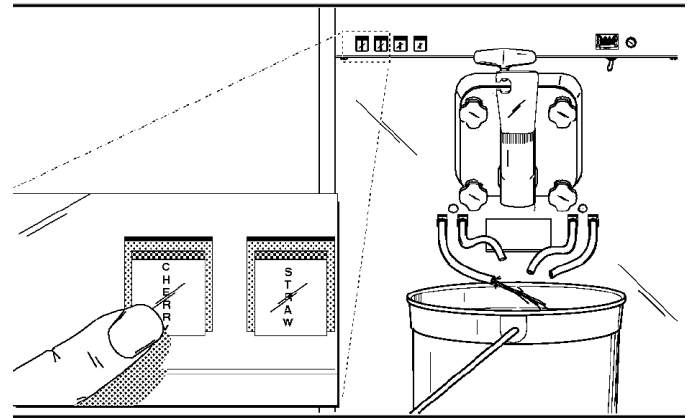

Figure 6-53

Note: This procedure will thoroughly clean the ends of the syrup lines that attach to the spinner housing to prevent bacteria buildup.

8. Disconnect the No. 1 air and syrup lines from the tank now partially filled with sanitizer.
9. Connect the No. 2 air and syrup lines to the tank and repeat the procedure by pressing the second flavor button from the left, and so on, until all three syrup lines have been cleaned and sanitized.
10. The fourth syrup line is for the spinner rinse. To effectively sanitize the end of this syrup line, use a small amount of fresh sanitizer on a brush and brush-clean the end of the fourth syrup line. Press the spinner rinse button to further flush this rinse line. **Repeat this step** for each syrup line.
11. Disconnect the air line and syrup line from the tank with the remaining sanitizer in it. Remove the tank lid and pour out all the remaining sanitizing solution. Place the tank in an upside down on a clean, dry surface to air-dry.
12. Attach the syrup lines to the spinner housing.
13. Remove the freezer door and the draw valve.

During Cleaning and Sanitizing

Cleaning and sanitizing schedules are governed by your state or local regulatory agencies and must be followed accordingly. If the machine has a **Standby mode**, it must not be used instead of proper cleaning and sanitizing procedures and frequencies set forth by the ruling health authority. The following checkpoints should be stressed during the cleaning and sanitizing operations.

Important! Cleaning and sanitizing must be performed daily.



ALWAYS FOLLOW LOCAL HEALTH CODES.

Troubleshooting Bacterial Count

- Thoroughly clean and sanitize the machine regularly, including complete disassembly and brush-cleaning.
- Use all the brushes supplied for thorough cleaning. The brushes are specially designed to reach all the mix passageways.
- Use the bristle brush to clean the mix inlet hole, which extends from the mix hopper down to the rear of the freezing cylinder.
- Use the black bristle brush to thoroughly clean the rear shell bearing at the rear of the freezing cylinder. Use a generous amount of cleaning solution on the brush.
- If local health codes permit the use of rerun** make sure it is stored in a sanitized, covered stainless-steel container and used the following day. **Do not** prime the machine with rerun. When using rerun, skim off foam and discard, then add **fresh** mix in a ratio of 50:50 during the day's operation.
- On a designated day of the week, run the mix as low as feasible and discard after closing. This will break the rerun cycle and reduce the possibility of high bacteria and coliform counts.
- Properly prepare the cleaning and sanitizing solutions. Read and follow the label directions carefully. Too **strong** of a solution may damage the parts, while too **weak** of a solution will not do an adequate job of cleaning or sanitizing.
- Empty all syrup from the tanks and discard at least once a week.
- Thoroughly clean and sanitize the syrup lines at least once a week.
- The temperature of mix in the mix hopper and walk-in cooler should be below 40°F (4.4°C).

Regular Maintenance Checks

- Rotate the scraper blades to allow both sides of the knife edge to wear evenly. This will contribute to self-sharpening and help maintain fast, efficient freezing.
- Replace scraper blades that are bent, damaged, or worn.
- Before installing the beater, make sure that the scraper blades are properly attached over the beater pins.
- Check the rear shell bearing for signs of wear (excessive mix leakage in drip pan) and make sure it is properly cleaned.
- Using a screwdriver and cloth towel, clean the rear shell bearing and the female hex drive socket free of lubricant and mix deposits.
- Dispose of O-rings and seals if they are worn, torn, or fit too loosely, and replace with new ones.

OPERATOR'S CHECKLIST

- Follow all lubricating procedures as outlined in Assembly on page 6-1.
- On air-cooled machines, check the condenser for dirt and lint. A dirty condenser will reduce the efficiency and capacity of the machine. The condenser should be cleaned monthly with a soft brush. Never use screwdrivers or other metal probes to clean between the fins.

***Note:** For machines equipped with an air filter, it will be necessary to vacuum-clean the filters monthly.*

- On water-cooled machines, check the water lines for kinks or leaks. Kinks can occur when the machine is moved back and forth for cleaning or maintenance. Deteriorated or cracked water lines should be replaced by a Taylor service technician only.

Winter Storage

If the place of business is to be closed during the winter months, it is important to protect the machine by following certain precautions, particularly if the building is subject to freezing conditions.

Disconnect the freezer from the main power source to prevent possible electrical damage.

On water-cooled machines, disconnect the water supply. Relieve pressure on the spring in the water valve. Use air pressure on the outlet side to blow out any water remaining in the condenser. **This is extremely important.** Failure to follow this procedure may cause severe damage to the refrigeration system.

Your local Taylor distributor can perform this service for you.

Wrap detachable parts of the machine (such as the beater, blades, driveshaft, and freezer door) and place them in a dry, protected place. Rubber trim parts and gaskets can be protected by wrapping them with moisture-proof paper. All parts should be thoroughly cleaned of dried mix or lubricant, which can attract mice and other vermin.

Table 8-1

Problem	Probable Cause	Remedy	Page Ref.
1. No product being dispensed.	a. There is an inadequate amount of mix in the hopper.	a. Fill the hopper with mix.	6-8
	b. Control switch is in the OFF position.	b. Place control switch in the AUTO position	6-8
	c. There is a freeze-up in the mix inlet hole.	c. Call a service technician to adjust hopper temperature.	
	d. Beater motor out on reset.	d. Reset freezer.	5-2
	e. Beater rotating counterclockwise.	e. Call a service technician to correct rotation. Should rotate clockwise from the operator's end.	---
	f. Beater motor will not activate with draw arm in the raised position.	f. An electrical problem requiring a service call.	---
	g. Frozen clumps of product blocking flow of mix to freezing cylinder.	g. Improper handling of rerun. Rerun must be thawed completely and foam must be skimmed off. Always mix 50% fresh mix with 50% rerun.	7-1
	h. Draw arm not engaged in draw valve.	h. Center the draw valve on the draw arm.	6-5
2. The product is too stiff.	a. Improper lubrication of torque rotor O-rings.	a. Lubricate the O-rings properly.	6-2
	b. Improper consistency control adjustment.	b. Product should be dispensed at 26°F to 28°F (-3.3°C to -2.2°C).	5-3
	c. The torque rotor is binding.	c. Before installing the torque arm, check to see if the torque rotor can be rotated freely without binding.	6-5
	d. Not enough syrup being blended with product.	d. Calibrate the syrup system. Syrup delivery should be 1 oz. (29.6 ml) in 6 seconds.	6-9
	e. Torque arm not installed.	e. Install torque arm.	6-5
3. The product is too soft.	a. Improper consistency control adjustment.	a. Product should be dispensed at 26°F to 28°F (-3.3°C to -2.2°C).	5-3
	b. The torque rotor is binding.	b. Before installing the torque arm, check to see if the torque rotor can be rotated freely without binding.	6-5
	c. Improper lubrication of torque rotor O-rings.	c. Lubricate the O-rings properly.	6-2
	d. Lubrication of torque rotor guide bearing.	d. Do not lubricate the guide bearing.	6-2
	e. Too much syrup being blended with product.	e. Calibrate the syrup system. Syrup delivery should be 1 oz. (29.6 ml) in 6 seconds.	6-9
	f. Bad scraper blades.	f. Replace scraper blades.	6-2
	g. Dirty condenser (air-cooled)	g. Brush condenser clean every 30 days.	7-1

TROUBLESHOOTING GUIDE

Problem	Probable Cause	Remedy	Page Ref.
4. Large pressure adjustments are necessary to receive 1 oz. (29.6 ml.) in 6 seconds.	a. Hardened syrup in syrup line.	a. Sanitize syrup lines once a week.	6-14
	b. Syrup line and air line not matched properly to syrup tank.	b. Match syrup and air lines to syrup tank.	6-9
5. The mix hopper is too warm.	a. Product too warm when placed in hopper.	a. Check temperature in storage cooler.	7-1
	b. Control switch in the OFF position.	b. Place in AUTO position.	6-8
	c. The temperature is out of adjustment.	c. Call a service technician to adjust hopper temperature.	---
6. The mix hopper is too cold.	a. The temperature is out of adjustment.	a. Call a service technician to adjust hopper temperature.	---
7. Machine short cycling (rapid on and off cycles).	b. Dirty air-cooled condenser.	b. Brush-clean every 30 days.	7-2
	c. Inadequate water supply on water-cooled unit.	c. Check water supply.	1-2
	d. Defective condenser fan.	d. Call service to repair or replace.	---
	e. No airspace surrounding machine.	e. Maintain specified air clearance.	1-2
	a. The scraper blades are damaged.	a. Replace the scraper blades.	6-2
8. The freezing cylinder walls are scored.	b. Machine was placed in AUTO before all sanitizing solution was removed from freezing cylinder.	b. Place machine in AUTO only after priming is complete and all sanitizing solution is removed.	6-7
	c. The front bearing is missing or worn on the freezer door.	c. Install or replace the front bearing.	6-4
	d. The beater assembly is bent.	d. Call a service technician to repair or replace beater and to correct cause of insufficient mix in freezing cylinder.	---
	e. The beater pins are broken.	e. Call service technician to repair or replace.	---
	a. Lubrication on hex end of shaft.	a. Call service technician for removal.	---
9. The driveshaft is stuck in the gearbox coupling.	b. Rounded corners of hex end of driveshaft.	b. Replace defective driveshaft.	---
	a. Rounded corners of coupling on gearbox.	a. Call service technician to replace gearbox.	---
10. Excessive mix leakage into the rear drip pan.	a. Worn or missing seal on driveshaft.	a. Replace every 3 months.	9-1
	b. Inadequate lubrication of driveshaft.	b. Follow lubrication procedures in Assembly on page 6-1.	6-2
	c. Bad rear shell bearing.	c. Call service technician to replace rear shell bearing.	---
	d. Driveshaft and beater working forward.	d. Call service technician.	---

Problem	Probable Cause	Remedy	Page Ref.
11. Machine will not operate when control switch is in the AUTO position.	<ul style="list-style-type: none"> a. Draw arm not raised. b. Circuit breaker off or blown fuse. c. Beater motor out on reset. d. Water turned off (water-cooled machines). a. Machine unplugged. 	<ul style="list-style-type: none"> a. Raise draw arm momentarily to activate system. b. Turn circuit breaker on or replace fuse. c. Clear the tone and reset freezer. d. Re-establish water supply. a. Plug into wall receptacle. 	<p>6-8</p> <p>---</p> <p>5-2</p> <p>1-2</p> <p>---</p>
12. Water continues to flow through spinner housing.	<ul style="list-style-type: none"> a. Rinse solenoid stuck open. 	<ul style="list-style-type: none"> a. Call service technician for repair. 	<p>---</p>
13. Lift motor continues to raise draw valve after draw of product has been made.	<ul style="list-style-type: none"> a. Micro switch needs adjustment. 	<ul style="list-style-type: none"> a. Call service technician for repair. 	<p>---</p>
14. Air compressor runs too often for normal usage.	<ul style="list-style-type: none"> a. Air leak in system. 	<ul style="list-style-type: none"> a. Use a soap solution to locate the leak. 	<p>---</p>
15. Spinner shaft will not rotate to blend syrup into product.	<ul style="list-style-type: none"> a. Flexible cable broken. b. Pin missing in female quick disconnect. a. Spinner motor out on thermal overload. 	<ul style="list-style-type: none"> a. Call service technician to replace cable. b. Call service technician to replace disconnect. a. Inadequate lubrication of spinner shaft. Lubricate entire length of shaft. 	<p>---</p> <p>---</p> <p>6-5</p>
16. Excessive drippage of product from spinner housing.	<ul style="list-style-type: none"> a. The draw valve O-rings are worn or missing. b. Wrong O-rings on draw valve. c. Inadequate lubrication of spinner shaft. 	<ul style="list-style-type: none"> a. Replace every 3 months. b. Check O-ring size. c. Follow lubrication procedures in Assembly. 	<p>9-1</p> <p>---</p> <p>6-5</p>

Section 9

Parts Replacement Schedule

Table 9-1

Part Description	Every 3 Months	Every 6 Months	Annually	Qty.
Driveshaft Seal	X			1
Scraper Blades	Inspect and replace if necessary.	Minimum		2
Front Bearing	X			1
Freezer Door Gasket	X			1
Draw Valve O-rings	X			2
Torque Rotor Guide Bearing	X			1
Torque Rotor O-rings	X			2
Feed Assembly O-ring	X			2
Double Ended Brush		Inspect and replace if necessary.	Minimum	1
Black Bristle Brush, 1" x 2"		Inspect and replace if necessary.	Minimum	1
Bristle Brush, 1-1/2" x 2"		Inspect and replace if necessary.	Minimum	1
Bristle Brush, 3" x 7"		Inspect and replace if necessary.	Minimum	1

Tune-up kits are available from your Taylor distributor. Keep your freezer in top condition with the above replacement parts in a Tune-up kit for your model of freezer. Ask your Taylor distributor about the Automatic 3-Month Tune-Up Kit Mailing Program.

TAYLOR COMPANY LIMITED WARRANTY ON FREEZERS

Taylor Company is pleased to provide this limited warranty on new Taylor-branded freezer machines available from Taylor to the market generally (the "Product") to the original purchaser only.

LIMITED WARRANTY

Taylor warrants the Product against failure due to defect in materials or workmanship under normal use and service as follows. All warranty periods begin on the date of original Product installation. If a part fails due to defect during the applicable warranty period, Taylor, through an authorized Taylor distributor or service agency, will provide a new or remanufactured part, at Taylor's option, to replace the failed defective part at no charge for the part. Except as otherwise stated herein, these are Taylor's exclusive obligations under this limited warranty for a Product failure. This limited warranty is subject to all provisions, conditions, limitations, and exclusions listed below and on the reverse (if any) of this document.

Table 10-1

Product	Part	Limited Warranty Period
Soft Serve	Insulated shell assembly	Five (5) years
Frozen Yogurt Shakes	Refrigeration compressor (except service valve)	Five (5) years
Smoothies	Beater motors	Two (2) years
Frozen Beverage	Beater drive gear	Two (2) years
Batch Desserts	Printed circuit boards and Softech™ controls beginning with serial number H8024200	Two (2) years
	Parts not otherwise listed in this table or excluded below	One (1) years

LIMITED WARRANTY CONDITIONS

1. If the date of original installation of the Product cannot be verified, then the limited warranty period begins ninety (90) days from the date of Product manufacture (as indicated by the Product serial number). Proof of purchase may be required at time of service.
2. This limited warranty is valid only if the Product is installed and all required service work on the Product is performed by an authorized Taylor distributor or service agency, and only if genuine, new Taylor parts are used.
3. Installation, use, care, and maintenance must be normal and in accordance with all instructions contained in the Taylor Operator's Manual.
4. Defective parts must be returned to the authorized Taylor distributor or service agency for credit.
5. The use of any refrigerant other than that specified on the Product's data label will void this limited warranty.

LIMITED WARRANTY EXCEPTIONS

This limited warranty does **not** cover:

1. Labor or other costs incurred for diagnosing, repairing, removing, installing, shipping, servicing, or handling of defective parts, replacement parts, or new Products.
2. Normal maintenance, cleaning, and lubrication as outlined in the Taylor Operator's Manual, including cleaning of condensers.

LIMITED WARRANTY ON EQUIPMENT

3. Replacement of wear items designated as Class "000" parts in the Taylor Operator's Manual.
4. External hoses, electrical power supplies, and machine grounding.
5. Parts not supplied or designated by Taylor, or damages resulting from their use.
6. Return trips or waiting time required because a service technician is prevented from beginning warranty service work promptly upon arrival.
7. Failure, damage, or repairs due to faulty installation, misapplication, abuse, no or improper servicing, unauthorized alteration, or improper operation or use as indicated in the Taylor Operator's Manual, including but not limited to the failure to use proper assembly and cleaning techniques, tools, or approved cleaning supplies.
8. Failure, damage, or repairs due to theft, vandalism, wind, rain, flood, high water, water, lightning, earthquake, or any other natural disaster, fire, corrosive environments, insect or rodent infestation, or other casualty, accident, or condition beyond the reasonable control of Taylor; operation above or below the electrical or water supply specification of the Product; or components repaired or altered in any way so as, in the judgment of the Manufacturer, to adversely affect performance, or normal wear or deterioration.
9. Any Product purchased over the internet.
10. Failure to start due to voltage conditions, blown fuses, open circuit breakers, or damages due to the inadequacy or interruption of electrical service.
11. Electricity or fuel costs, or increases in electricity or fuel costs from any reason whatsoever.
12. Damages resulting from the use of any refrigerant other than that specified on the Product's data label will void this limited warranty.
13. Any cost to replace, refill, or dispose of refrigerant, including the cost of refrigerant.
14. **ANY SPECIAL, INDIRECT, OR CONSEQUENTIAL PROPERTY OR COMMERCIAL DAMAGE OF ANY NATURE WHATSOEVER.** Some jurisdictions do not allow the exclusion of incidental or consequential damages, so this limitation may not apply to you.

This limited warranty gives you specific legal rights, and you may also have other rights which vary from jurisdiction to jurisdiction.

LIMITATION OF WARRANTY

THIS LIMITED WARRANTY IS EXCLUSIVE AND IS IN LIEU OF ALL OTHER WARRANTIES, CONDITIONS, AND/OR REMEDIES UNDER THE LAW, INCLUDING ANY IMPLIED WARRANTIES OR CONDITIONS OF MERCHANTABILITY OR FITNESS FOR A PARTICULAR PURPOSE. THE ORIGINAL OWNER'S SOLE REMEDY WITH RESPECT TO ANY PRODUCTS SHALL BE REPAIR OR REPLACEMENT OF DEFECTIVE COMPONENTS UNDER THE TERMS OF THIS LIMITED WARRANTY. ALL RIGHTS TO CONSEQUENTIAL OR INCIDENTAL DAMAGES (INCLUDING CLAIMS FOR LOST SALES, LOST PROFITS, PRODUCT LOSS, PROPERTY DAMAGES, OR SERVICE EXPENSES) ARE EXPRESSLY EXCLUDED. THE EXPRESS WARRANTIES MADE IN THIS LIMITED WARRANTY MAY NOT BE ALTERED, ENLARGED, OR CHANGED BY ANY DISTRIBUTOR, DEALER, OR OTHER PERSON, WHATSOEVER.

LEGAL REMEDIES

10 The owner **must** notify Taylor in writing, by certified or registered letter to the following address, of any defect or complaint with the Product, stating the defect or complaint and a specific request for repair, replacement, or other correction of the Product under warranty, mailed at least thirty (30) days before pursuing any legal rights or remedies.

Taylor Company
750 N. Blackhawk Blvd.
Rockton, IL 61072, U.S.A.

TAYLOR COMPANY LIMITED WARRANTY ON TAYLOR GENUINE PARTS

Taylor Company is pleased to provide this limited warranty on new Taylor genuine replacement components and parts available from Taylor to the market generally (the "Parts") to the original purchaser only.

LIMITED WARRANTY

Taylor warrants the Parts against failure due to defect in materials or workmanship under normal use and service as follows. All warranty periods begin on the date of original installation of the Part in the Taylor machine. If a Part fails due to defect during the applicable warranty period, Taylor, through an authorized Taylor distributor or service agency, will provide a new or remanufactured Part, at Taylor's option, to replace the failed defective Part at no charge for the Part. Except as otherwise stated herein, these are Taylor's exclusive obligations under this limited warranty for a Part failure. This limited warranty is subject to all provisions, conditions, limitations, and exclusions listed below and on the reverse (if any) of this document.

Table 11-1

Part's Warranty Class Code Or Part	Limited Warranty Period
Class 103 Parts ¹	Three (3) Months
Class 212 Parts ²	Twelve (12) Months
Class 512 Parts	Twelve (12) Months
Class 000 Parts	No Warranty

LIMITED WARRANTY CONDITIONS

1. If the date of original installation of the Part cannot be otherwise verified, proof of purchase may be required at time of service.
2. This limited warranty is valid only if the Part is installed and all required service work in connection with the Part is performed by an authorized Taylor distributor or service agency.
3. The limited warranty applies only to Parts remaining in use by their original owner at their original installation location in the machine of original installation.
4. Installation, use, care, and maintenance must be normal and in accordance with all instructions contained in the Taylor Operator's Manual.
5. Defective Parts must be returned to the authorized Taylor distributor or service agency for credit.
6. This warranty is not intended to shorten the length of any warranty coverage provided pursuant to a separate Taylor Limited Warranty on freezer or grill machines.
7. The use of any refrigerant other than that specified for the machine in which the Part is installed will void this limited warranty.

^{1, 2} Except that Taylor Part #032129SER2 (Compressor-Air-230V SERV) and Taylor Part #075506SER1 (Compressor-Air-115V 60HZ) shall have a limited warranty period of twelve (12) months when used in Taylor freezer machines and a limited warranty period of two (2) years when used in Taylor grill machines.

LIMITED WARRANTY ON PARTS

LIMITED WARRANTY EXCEPTIONS

This limited warranty does **not** cover:

1. Labor or other costs incurred for diagnosing, repairing, removing, installing, shipping, servicing, or handling of defective Parts, replacement Parts, or new Parts.
2. Normal maintenance, cleaning, and lubrication as outlined in the Taylor Operator's Manual, including cleaning of condensers or carbon and grease buildup.
3. Required service, whether cleaning or general repairs, to return the cooking surface assemblies, including the upper platen and lower plate, to an operational condition to achieve proper cooking or allow proper assembly of release sheets and clips as a result of grease buildup on the cooking surfaces, including but not limited to the platen and plate, sides of the shroud, or top of the shroud.
4. Replacement of cooking surfaces, including the upper platen and lower plate, due to pitting or corrosion (or in the case of the upper platen, due to loss of plating) as a result of damage due to the impact of spatulas or other small wares used during the cooking process or as a result of the use of cleaners, cleaning materials, or cleaning processes not approved for use by Taylor.
5. Replacement of wear items designated as Class "000" Parts in the Taylor Operator's Manual, as well as any release sheets and clips for the Product's upper platen assembly.
6. External hoses, electrical power supplies, and machine grounding.
7. Parts not supplied or designated by Taylor, or damages resulting from their use.
8. Return trips or waiting time required because a service technician is prevented from beginning warranty service work promptly upon arrival.
9. Failure, damage, or repairs due to faulty installation, misapplication, abuse, no or improper servicing, unauthorized alteration, or improper operation or use as indicated in the Taylor Operator's Manual, including but not limited to the failure to use proper assembly and cleaning techniques, tools, or approved cleaning supplies.
10. Failure, damage, or repairs due to theft, vandalism, wind, rain, flood, high water, water, lightning, earthquake, or any other natural disaster, fire, corrosive environments, insect or rodent infestation, or other casualty, accident or condition beyond the reasonable control of Taylor; operation above or below the gas, electrical, or water supply specification of the machine in which a part is installed; or Parts or the machines in which they are installed repaired or altered in any way so as, in the judgment of Taylor, to adversely affect performance, or normal wear or deterioration.
11. Any Part purchased over the internet.
12. Failure to start due to voltage conditions, blown fuses, open circuit breakers, or damages due to the inadequacy or interruption of electrical service.
13. Electricity, gas, or other fuel costs, or increases in electricity or fuel costs from any reason whatsoever.
14. Damages resulting from the use of any refrigerant other than that specified for the machine in which the Part is installed will void this limited warranty.
15. Any cost to replace, refill, or dispose of refrigerant, including the cost of refrigerant.
16. **ANY SPECIAL, INDIRECT, OR CONSEQUENTIAL PROPERTY OR COMMERCIAL DAMAGE OF ANY NATURE WHATSOEVER.** Some jurisdictions do not allow the exclusion of incidental or consequential damages, so this limitation may not apply to you.

This limited warranty gives you specific legal rights, and you may also have other rights which vary from jurisdiction to jurisdiction.

LIMITATION OF WARRANTY

THIS LIMITED WARRANTY IS EXCLUSIVE AND IS IN LIEU OF ALL OTHER WARRANTIES, CONDITIONS, AND/OR REMEDIES UNDER THE LAW, INCLUDING ANY IMPLIED WARRANTIES OR CONDITIONS OF MERCHANTABILITY OR FITNESS FOR A PARTICULAR PURPOSE. THE ORIGINAL OWNER'S SOLE REMEDY WITH RESPECT TO ANY PRODUCTS SHALL BE REPAIR OR REPLACEMENT OF DEFECTIVE PARTS UNDER THE TERMS OF THIS LIMITED WARRANTY. ALL RIGHTS TO CONSEQUENTIAL OR INCIDENTAL DAMAGES (INCLUDING CLAIMS FOR LOST SALES, LOST PROFITS, PRODUCT LOSS, PROPERTY DAMAGES, OR SERVICE EXPENSES) ARE EXPRESSLY EXCLUDED. THE EXPRESS WARRANTIES MADE IN THIS LIMITED WARRANTY MAY NOT BE ALTERED, ENLARGED, OR CHANGED BY ANY DISTRIBUTOR, DEALER, OR OTHER PERSON, WHATSOEVER.

LEGAL REMEDIES

The owner **must** notify Taylor in writing, by certified or registered letter to the following address, of any defect or complaint with the Part, stating the defect or complaint and a specific request for repair, replacement, or other correction of the Part under warranty, mailed at least thirty (30) days before pursuing any legal rights or remedies.

Taylor Company
750 N. Blackhawk Blvd.
Rockton, IL 61072, U.S.A.

Notes:

Lined area for notes with 25 horizontal lines.