

PROJECT	QUANTITY	ITEM NO
---------	----------	---------

# Pressure Fryers

**PFG 600** Gas



PFG 600 gas pressure fryer with Computron™ 8000 control

Henny Penny first introduced commercial pressure frying to the foodservice industry more than 50 years ago. Frying under pressure enables lower cooking temperatures for longer oil life, and faster cooking times to meet peak demand. Pressure also seals in food's natural juices and reduces the amount of oil absorbed into product.

Today, Henny Penny pressure fryers continue to lead the industry in performance, durability and innovation.

The Henny Penny PFG 600 gas pressure fryer recovers temperature very quickly through extremely efficient heat exchange, producing among the industry's lowest average exhaust gas temperatures. Fast recovery translates into higher

throughput, lower energy costs and longer frying oil life.

Henny Penny pressure fryers have a patented lid lock and color-keyed spindle that make it easy to create a perfect pressure seal every time.

A built-in filtration system filters and returns hot frying oil in minutes. No separate pumps and pans, no handling hot oil.

The Computron™ 8000 control features automatic, programmable operation, as well as energy-saving, filtration and cook management functions.

The Computron™ 1000 control offers programmability in a simple, easy to use digital control panel with LED display.

## Standard Features

- Patented lid-lock system keeps lid locked until pressure reaches 1 psi
- Color-keyed locking spindle engages pressure seal
- Heavy-duty stainless steel fry pot with 7-year warranty
- High-efficiency burner with solid state ignition
- Rectangular fry pot design promotes turbulence for even cooking
- Cold zone below burners helps extend oil life
- High-limit temperature protection
- Built-in filtration system
- Cast aluminum alloy lid is strong but light for easy handling
- Channel under lid directs condensation away from pot when lid is up
- Raised edge on deck reduces spills
- Stainless steel construction for easy-cleaning and long life
- Narrow footprint saves floor space and cookline frontage
- 4 heavy-duty casters, 2 locking
- Computron™ 8000 control (additional charge)
  - 10 programmable cook cycles
  - Melt mode
  - Idle mode
  - Clean-out mode
  - Water detection alert
  - Load compensation
  - Proportional control
  - Optional filter prompt and customizable filter tracking
  - 16-character digital display with multiple language settings
- Computron™ 1000 control
  - Programmable
  - LED Time/Temp display
  - Simple UP/DOWN arrows

## Accessories shipped with unit

Filter screen with standard filter media (2 PHT filter envelopes)

## Accessories and options available separately

- 3-tiered basket
- Locking basket handle
- Full-size basket and handle
- Crumb pan and handle
- Filter pan dolly
- Choose one:
  - Filter rinse hose OR
  - Direct Connect shortening disposal

<input type="checkbox"/> APPROVED	<input type="checkbox"/> APPROVED AS NOTED	<input type="checkbox"/> RESUBMIT
AUTHORIZED SIGNATURE		DATE



PROJECT	ITEM NO
---------	---------

# Pressure Fryers

**PFG 600 Gas**

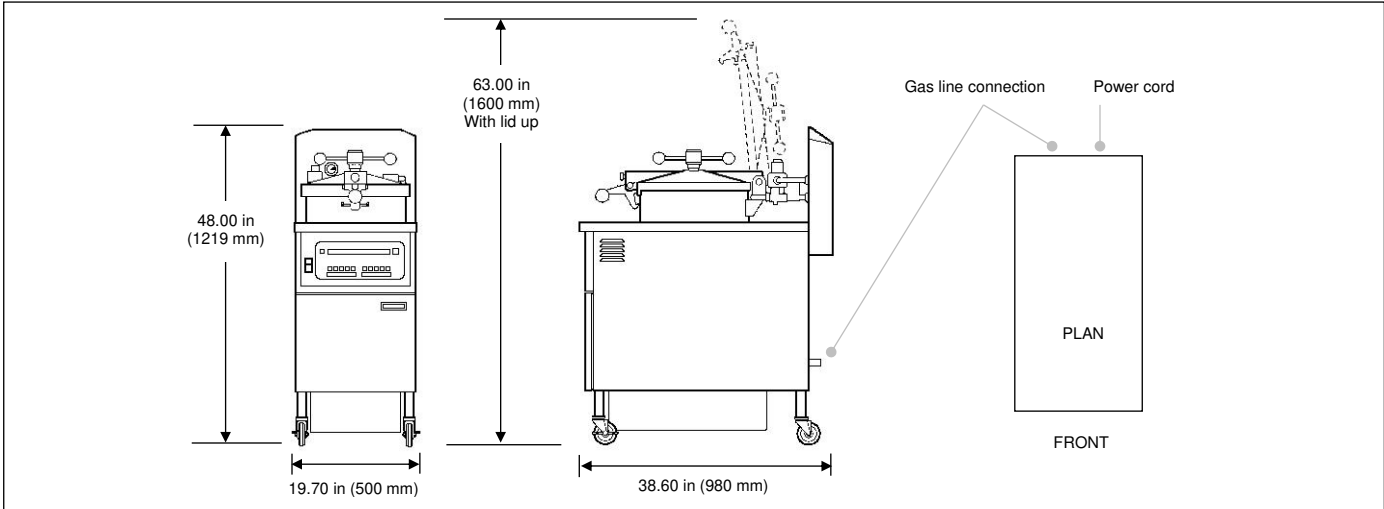

**Dimensions**

Height 48.00 in (1219 mm) to top of stack  
 Height 63.00 in (1575 mm) with lid up  
 Width 19.70 in (483 mm)  
 Depth 38.60 in (980 mm)

**Crated**

Length 44 in (1118 mm)  
 Depth 27 in (686 mm)  
 Height 56 in (1420 mm)  
 Volume 39 ft<sup>3</sup> (1.1 m<sup>3</sup>)  
 Weight 380 lb (172 kg)

**Required clearances**

Top 15 in (381 mm) lid up  
 Sides 6 in (152 mm) air flow, minimum 1 side  
 Back 6 in (152 mm) air flow, connections  
 Front 30 in (762 mm) remove filter pan

**Pressure**

Operating pressure 12.0 psi  
 Safety valve setting 14.5 psi

**Heating**

Natural gas or liquid petroleum  
 1 burner  
 0.50 in gas line  
 80,000 BTU/hr or 21.1 kW

**Oil capacity**

43 lb or 22 L

**Bidding specifications**

Provide Henny Penny model PFG 600 gas pressure fryer, 4 head capacity, with built-in filtration system.

Unit shall incorporate:

- Computron™ 1000 simple digital control OR Computron™ 8000 control system (additional charge) with programmable or manual operation, LED digital display, idle and melt modes, load compensation, filtration tracking and 7-day history
- Fry pot of heavy duty stainless steel with 7-year warranty
- Color-keyed locking spindle and lid-lock system to seal and create and maintain 12 psi pressure in cooking chamber
- 4 heavy-duty casters, 2 locking
- Starter kit with choice of filter media

**Electrical**

Volts	Phase	Hertz	kW	Amps	Wire*	Cord & Plug (optional)
120	1	60	1.15	10.0	2+G	120 V only
190-208	1	50 or 60	1.15	6.0	2+G	 NEMA 5-15P
220-240	1	50 or 60	1.15	6.0	2+G	
230	1	50	1.15	2.5	1NG	

**Laboratory certifications**



\*Units shipped without power cord and plug must have power cord and plug installed on site by a qualified electrician.

Continuing product improvement may subject specifications to change without notice.

**24 Hour Technical Support:**  
 Henny Penny Technical Service  
 800 417.8405  
[technicalservices@hennypenny.com](mailto:technicalservices@hennypenny.com)

**Henny Penny Corporation**  
 PO Box 60 Eaton OH 45320 USA  
 +1 937 456.8400 800 417.8417  
 +1 937 456.8434 Fax 800 417.8434 Fax  
[www.hennypenny.com](http://www.hennypenny.com)

