

PROJECT	QUANTITY	ITEM NO
---------	----------	---------

Display counter warmers

Full serve, humidified

CW 114 Single tier
CW 216 Two tier



CW 114 single tier and CW 216 two tier display counter warmers

Henny Penny display counter warmers are designed for accumulating, holding and displaying hot fresh food for serving or packing at the point of sale in retail foodservice operations.

Solid tempered glass front and removable sliding glass control side doors make the Henny Penny CW counter warmers ideal for up front fresh food presentation and convenient customer service.

The CW 114 is a single tier unit with upper and lower heat, and water reservoir humidity. The two-tiered CW 216 offers two separate holding environments, giving operators the versatility to hold and display a variety of menu items at the same time. The lower tier operates with water reservoir humidity. The upper tier operates with dry heat only. Both tiers in the CW 216 have upper and lower heat.

Humidity in the CW 114 and lower tier of the CW 216 is generated by a full-length heated auto-fill reservoir in the base. Separate temperature controls for reservoir and heating for each tier. Units are also designed to accommodate steam table pans as well as sheet pans, further increasing the variety of foods that can be profitably displayed.

Units are built from high quality tempered glass and stainless steel, and are insulated for energy efficient operation.

Standard features

- Single tier CW 114 features upper and lower heat with water reservoir humidity
- Lower tier in CW 216 features humidified operation, upper tier operates with dry heat only
- Long-lasting sheath radiant sheath heaters provide direct heating over food
- Lower element heaters under pans
- Separate controls for upper tier heat, lower tier heat, water temperature
- Humidified operation
 - Full length water reservoir with automatic or manual fill
 - Two water well strip heaters
 - Water temperature display and control
 - Low water indicator light
 - Drain tube prevents water well overflow
- Angled solid front glass for up front display, removable sliding rear doors for convenient service
- Accepts steam table pans or sheet pans
- Insulated top and bottom for energy efficient operation
- Incandescent lighting for appealing food presentation
- Removable access panels for easy service
- Stainless steel and tempered glass construction for easy cleaning and long life

Options

- Sliding glass doors on customer side (additional charge)

<input type="checkbox"/> APPROVED	<input type="checkbox"/> APPROVED AS NOTED	<input type="checkbox"/> RESUBMIT
AUTHORIZED SIGNATURE		DATE



Display counter warmers

Full serve, humidified

CW 114 Single tier
CW 216 Two tier

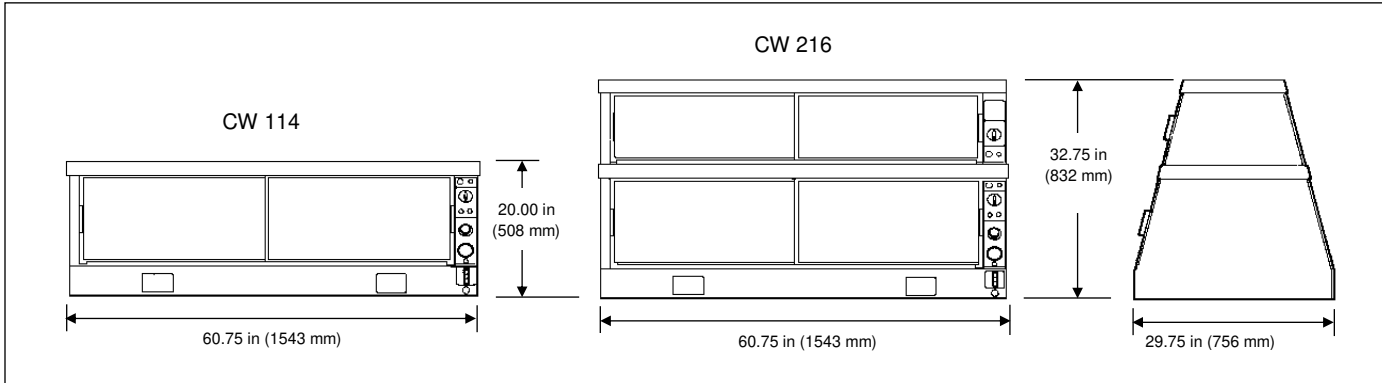

	CW 114 single tier		CW 216 two tier	
Dimensions				
Height	20.00 in	(508 mm)	32.75 in	(832 mm)
Width	60.75 in	(1543 mm)	60.75 in	(1543 mm)
Depth	29.75 in	(756 mm)	29.75 in	(756 mm)
Crated				
Length	62 in	(1580 mm)	62 in	(1580 mm)
Depth	33 in	(830 mm)	33 in	(830 mm)
Height	39 in	(990 mm)	39 in	(990 mm)
Volume	46 ft ³	(1.3 m ³)	46 ft ³	(1.3 m ³)
Weight	254 lb	(115 kg)	326 lb	(148 kg)
Capacity				
Lower tier	4 full-size steam table pans 4 in (102 mm) deep OR 3 full-size sheet pans 18 x 26 in (457 x 660 mm)		4 full-size steam table pans 4 in (102 mm) deep OR 3 full-size sheet pans 18 x 26 in (457 x 660 mm)	
Upper tier	N/A		4 two-thirds size steam table pans 2.5 in (64 mm) deep OR 2 full-size sheet pans 18 x 26 in (457 x 660 mm)	

Bidding specifications

Provide Henny Penny model CW 114 single tier or CW 216 two-tier display counter warmer designed to accumulate, hold and display freshly cooked food at the point of sale.

Unit shall incorporate:

- Overhead radiant heat and lower element heat under pans
- Lower tier humidified operation with full length auto-filled reservoir
- Upper tier in CW 216 operates dry only
- Solid tempered glass front, tempered glass sliding doors on control side (sliding doors on both sides available at additional cost)
- Separate controls for upper heat, lower heat, and water temperature
- Rear-mounted control panel with independent temperature control for upper and lower tiers
- Stainless steel interior and exterior construction

Humidity

Auto fill water reservoir with 0.25 in hot water connection + drain

Required clearances N/A

Electrical		CW 114		CW 216		Cord & Plug	
Volts	Phase	Hertz	kW	Amps	kW	Amps	Wire*
120/208	1	50/60	3.40	17.6	4.16	13.1	3+G
120/230	1	50/60	3.40	16.2	4.16	18.0	3+G
220-240	1	50/60	3.67	15.3	4.47	18.6	2+G
120/208	3	50/60	3.40	11.5	4.16	13.1	4+G
120/230	3	50/60	3.40	10.7	4.16	12.2	4+G
240	3	50/60	6.35	8.8	7.72	10.8	3+G
380-415 CE	3	50/60	3.40	5.0	4.16	6.0	3NG
380-415	3	50	3.67	5.1	4.47	6.2	4+G

Not available for all destinations

Please contact Henny Penny

Laboratory certifications



*Units shipped without power cord and plug must have power cord and plug installed on site by a qualified electrician.

Continuing product improvement may subject specifications to change without notice.

24 Hour Technical Support:
Henny Penny Technical Service
800 417.8405
technicalservices@hennypenny.com

Henny Penny Corporation
PO Box 60 Eaton OH 45320 USA
+1 937 456.8400 800 417.8417
+1 937 456.8434 Fax 800 417.8434 Fax
www.hennypenny.com

HENNY PENNY
Engineered to Last