

A1000



PRODUCT INFORMATION

The A1000 is the new standard in fully automatic coffee machines. With this latest innovation, leading manufacturer Franke is ready to take you to the next level of luxury. The A1000 was created to give all guests their very own little moment of luxury every day. No matter what their favorite coffee might be, the A1000 can fulfill their wishes.

The A1000 features up to 3 precision grinders with long-lasting ceramic grinding discs. A 10" intuitive touchscreen displays HD video along with sound. FoamMaster™ comes standard on the A1000. The automatic cleaning system, CleanMaster is standard on the A1000. Three high-performance boilers for hot water, preparing coffee, and steam deliver the high capacity level of the A1000.

The A1000 is the perfect solution for restaurants, convenience stores, quick-serve restaurants, schools, and much more.

FEATURES

- Intuitive touchscreen navigation on 10-inch panel with HD video and sound
- New intelligent refrigeration unit for up to two types of milk with two parallel refrigeration circuits, including FoamMaster™ milk foam
- Patented brew unit
- Up to three grinders
- Three boilers for hot water, coffee preparation, and steam for high capacity levels
- IoT - Access the A1000 from a smartphone or tablet
- Maximum energy efficiency
- Fully automatic cleaning system - CleanMaster
- Professional installation and 1 year scheduled maintenance program available
- 12 months parts and labor warranty

Make
it
wonderful

FRANKE

MACHINE MODEL A1000 FM CM

MODEL	POWER
A1000 FM CM	200-220 VAC 2LPE 30A Circuit 60 Hz 22.4-24.2 A Load 4.5-5.3 kW
Dimensions:	13.4 in / 28.7 in / 23.6 in (W/H/D)

COLOR OPTIONS

Black/chrome, black/gold, white/chrome or anthracite/chrome

WATER CONNECTION

Water connection	Metal hose with union nut G3/8", L = 59 in
Water supply line	If possible when installing: Untreated water (not from the domestic decalcification plant)
Water pressure	80 to 800 kPa (0.8 to 8.0 bar)
Water hardness	max. 70 mg CaO per liter of water (7 dH, 13 °fH)
Chloride content	max. 0.1 mg/l
Ideal pH value	7

WATER DRAIN

Drain hose Dia. = 0.6 in, L = 78.7 in

1) REFRIGERATION UNIT SU12/UC12 (12 L)

Electrical connection: 110-120 VAC 1LNPE 60 Hz 170-195 W

Dimensions:	13.4 in / 21.3 in / 18.7 in (W / H / D)
Weight (empty):	approx. 61 lbs
Colors:	Black, white, anthracite

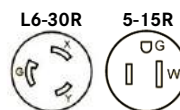
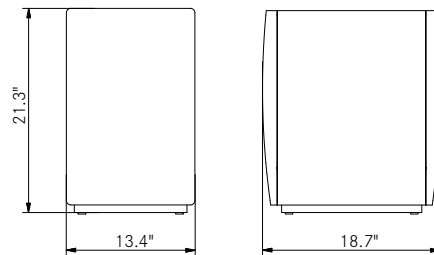
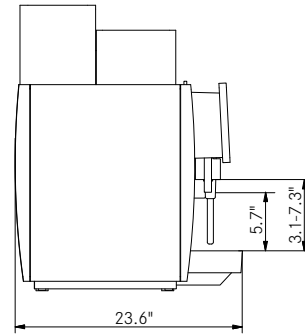
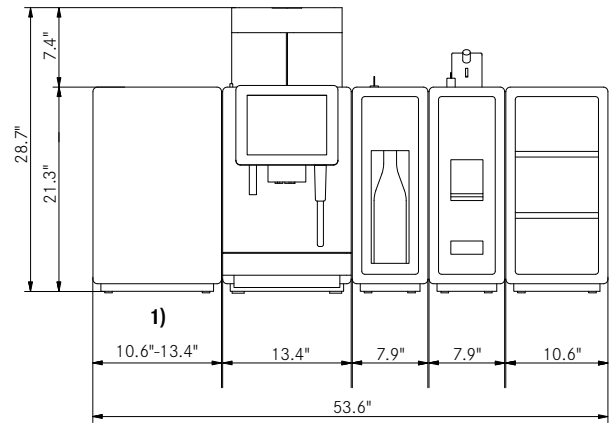

Franke Coffee Systems North America
800 Aviation Parkway
Smyrna TN 37167
T + 1 877 379 3769
coffee.franke.com

FRANKE